



## Notice

### About This Edition

Published by Philips  
Medical Systems

Printed in USA

Publication number  
453564106431

### Edition History

Edition 1, October 2008  
Software Revision  
A.01.00 and higher

### Warranty

Philips Medical Systems reserves the right to make changes to both this *Service Manual* and to the product that it describes. Product specifications are subject to change without notice.

Nothing contained within this *Service Manual* is intended as any offer, warranty, promise, or contractual condition, and must not be taken as such.

### Copyright

© 2008 Koninklijke  
Philips Electronics N.V.  
All rights are reserved. All  
other product names are  
the property of their  
respective owners.

Reproduction in whole or  
in part in any form, or by  
any means, electrical,  
mechanical or otherwise,  
is prohibited without the  
written consent of the  
copyright holder.

Philips Medical Systems  
3000 Minuteman Road  
Andover, MA 01810 USA  
(978) 687-1501

Unauthorized copying of  
this publication may not  
only infringe copyright  
laws, but may also reduce  
the ability of Philips  
Medical Systems to  
provide accurate and  
current information to  
users.

### Compliance

The Philips Medical  
Systems PageWriter TC70  
cardiograph complies with  
all relevant international  
and national standards and  
laws. Information on  
compliance will be  
supplied on request by a  
local Philips Medical  
Systems representative, or  
by the manufacturer.

### Intended Use of this Service Manual

This Philips product is  
intended to be operated  
only in accordance with  
the safety procedures and  
operating instructions  
provided in the *Service  
Manual*, and in accordance  
with the purposes for  
which it was designed.  
Installation, use, and oper-  
ation of this product is  
subject to the laws in  
effect in the jurisdiction(s)  
in which the product is  
being used. Users must  
only install, use, and  
operate this product in  
such a manner that does  
not conflict with appli-  
cable laws or regulations  
that have the force of  
law. Use of this product for  
purposes other than the  
express intended purpose  
provided by the manufac-  
turer, or incorrect use and  
operation, may relieve the  
manufacturer (or agent)  
from all or some responsi-  
bility for resultant non-  
compliance, damage, or  
injury.

United States federal law  
restricts this device to use  
by or on the order of a  
physician. THIS  
PRODUCT IS NOT  
INTENDED FOR HOME  
USE.

### Training

Users of this product must  
receive adequate clinical  
training on its safe and  
effective use before  
attempting to operate the  
product as described in  
this *Service Manual*.

Training requirements  
vary by country. Users  
must ensure that they  
receive adequate clinical  
training in accordance  
with local laws or regula-  
tions.

For further information on  
available training on the  
use of this product, please  
contact a Philips Medical  
Systems representative, or  
the manufacturer.

### Medical Device Directive

The PageWriter TC70  
Cardiograph complies  
with the requirements of  
the Medical Device Direc-  
tive 93/42/EEC and carries  
the **CE**<sub>0123</sub> mark accord-  
ingly.

Authorized EU-represen-  
tative:

Philips Medizin Systeme  
Böblingen GmbH  
Hewlett Packard Str. 2  
71034 Böblingen  
Germany

## Introduction

---

Who Should Use this Manual .....	1-3
Using the Philips InCenter Site .....	1-4
About Adobe Acrobat Versions .....	1-4
Safety Summary .....	1-5
Symbols Marked on the Cardiograph .....	1-5
Safety Symbols Marked on the Cardiograph Packaging .....	1-7
Safety and Regulatory Symbols Marked on the Cart .....	1-8
Safety and Regulatory Symbols Marked on the AC Power Adapter .....	1-9
Important Patient and Safety Information .....	1-10
Accessories and Supplies .....	1-10
AC Power Adapter and AC Power Cord .....	1-11
Analog ECG Output Signal Port .....	1-12
Batteries .....	1-12
Cart .....	1-12
Defibrillation .....	1-12
Diagrams .....	1-12
Display Accuracy .....	1-13
ECG Interpretation .....	1-13
Electrodes .....	1-13
Faxed ECGs .....	1-13
General Cardiograph Use .....	1-13
IEC 60601-2-51 .....	1-13
Lead Wires .....	1-14
Main Waveform Display Screen .....	1-14
Modem Card and Fax Feature .....	1-14
Pacemaker .....	1-14
Patient Data Cable .....	1-14
Patient Interface Module (PIM) .....	1-15
Printer .....	1-15
Servicing the Cardiograph .....	1-15
Software .....	1-15
Touch Screen .....	1-15
USB Memory Stick .....	1-16
PageWriter TC70 Cardiograph Components .....	1-16
Patient Interface Module (PIM) .....	1-19
Installing the Batteries .....	1-20
Charging the Batteries .....	1-22
Calibrating the Batteries .....	1-23
Battery Power Indicator .....	1-23
Using the Wireless LAN Card .....	1-24
Using the Modem Module .....	1-25
Using the USB Memory Stick .....	1-25
Using the Barcode Reader .....	1-27
Using the Keyboard Shortcuts .....	1-27

## Cardiograph Care and Maintenance

---

Cardiograph and PIM Cleaning . . . . .	2-3
Approved Cleaning Solutions . . . . .	2-3
Patient Data Cable and Lead Wire Cleaning . . . . .	2-4
Approved Cleaning Solutions . . . . .	2-4
Reusable Electrode Cleaning . . . . .	2-5
Cleaning the Print Head . . . . .	2-6
Printer Paper . . . . .	2-7
Tearing Paper . . . . .	2-10
Battery Maintenance and Care . . . . .	2-10
Replacing the Batteries . . . . .	2-11
Battery Calibration . . . . .	2-14
Maintaining the Touch Screen . . . . .	2-16
Touch Screen Calibration . . . . .	2-16
Touch Screen Cleaning . . . . .	2-16
Changing the Date and Time . . . . .	2-17
Cardiograph Overall Sensitivity Test . . . . .	2-18
Before You Begin . . . . .	2-18
Performing the Sensitivity Test . . . . .	2-18
Cardiograph and Accessory Disposal . . . . .	2-19

## Troubleshooting

---

Troubleshooting Cardiograph Issues . . . . .	3-2
Start up Issues . . . . .	3-3
Display Issues . . . . .	3-4
Keyboard Issues . . . . .	3-5
Signal Acquisition Issues . . . . .	3-7
Main Screen Issues . . . . .	3-10
Archive Screen Issues . . . . .	3-11
Configuration Screen Issues . . . . .	3-16
Printer Issues . . . . .	3-19
Compact Flash (CF) Card/USB Memory Stick Issues . . . . .	3-22
TraceMasterVue Issues . . . . .	3-25
Orders Issues . . . . .	3-27
Remote Query Issues . . . . .	3-29
Fax Issues . . . . .	3-31
Log File and Custom Settings Issues . . . . .	3-32
Wireless Troubleshooting . . . . .	3-33
Restarting the Cardiograph . . . . .	3-34
Running the Lead Wires Open Test . . . . .	3-35
Running the Lead Wires Short Test . . . . .	3-35

Running the Service Utilities . . . . .	3-36
Using the About the Cardiograph Screen . . . . .	3-37
Running the Diagnostic Tests and Utilities . . . . .	3-38
Running the Diagnostic Tests . . . . .	3-43
Viewing and Saving Log Files . . . . .	3-46
Saving Log Files . . . . .	3-47

## Performance Verification and Safety Tests

---

Required Testing Levels . . . . .	4-1
External Repairs . . . . .	4-2
Internal Repairs . . . . .	4-2
Upgrades . . . . .	4-3
Test and Inspection Matrix . . . . .	4-4
Test Equipment . . . . .	4-5
Performance Verification Tests . . . . .	4-6
Visual Inspection (V) . . . . .	4-6
Power On Test (PO) . . . . .	4-6
Individual Functional Tests . . . . .	4-7
Safety Tests . . . . .	4-12

## Parts and Supplies

---

Ordering Replacement Parts . . . . .	5-1
Replacement Parts . . . . .	5-2
Cart Replacement Parts . . . . .	5-4
Other Replacement Parts . . . . .	5-6
Ordering Supplies . . . . .	5-6
Special Note about Welsh Bulb Electrodes . . . . .	5-6
PageWriter TC70 Cardiograph Supply Part Numbers . . . . .	5-7
Ordering Options and Upgrades . . . . .	5-10
Contacting a Philips Response Center . . . . .	5-11

## Installing PageWriter TC 70 Software

---

Software Upgrades . . . . .	6-1
Obtaining Software . . . . .	6-1
Downloading Software Files from Philips InCenter . . . . .	6-1
Installing the Software Upgrade . . . . .	6-3
Before You Begin . . . . .	6-3
Verifying the Software Installation . . . . .	6-7

## Cart Assembly

---

Safety Summary . . . . .	7-3
Safety and Regulatory Symbols Marked on the Cart. . . . .	7-3
Important Patient and Safety Information . . . . .	7-3
Assembling the Cart . . . . .	7-3
Attaching the Cardiograph to the Cart . . . . .	7-6
Attaching Other Cart Accessories and Replacement Parts. . . . .	7-7

## Theory of Operation

---

Overview . . . . .	8-2
Hardware Logical View . . . . .	8-2
Main Board . . . . .	8-2
Display. . . . .	8-4
Patient Interface Module (PIM) . . . . .	8-4
Printer Control (FPGA) . . . . .	8-4
Battery (Lithium Ion) . . . . .	8-4
Keyboard and Buttons . . . . .	8-4
Touch Screen . . . . .	8-4
LAN Interface . . . . .	8-4
Magnetic Card Reader (PS/2) . . . . .	8-5
Barcode Reader (PS/2) . . . . .	8-5
Smart Card Reader. . . . .	8-5
USB Memory Stick . . . . .	8-5
Compact Flash Wireless LAN Card . . . . .	8-6
Modem Module. . . . .	8-6
High Level ECG Data Flow and Storage. . . . .	8-6
Internal Main Archive . . . . .	8-8
Internal Remote Archive . . . . .	8-8
External USB Memory Stick Archives . . . . .	8-8
Rendered ECG Report Prints . . . . .	8-8
Fax-Rendered ECG Report Print. . . . .	8-9
Power System Overview . . . . .	8-10
Battery . . . . .	8-10
Voltage Rails . . . . .	8-11
Power Management . . . . .	8-13
Battery Power Indicator. . . . .	8-14
Battery Discharging . . . . .	8-15
Battery Charging . . . . .	8-15
Charge Current . . . . .	8-15
Battery Information . . . . .	8-15

## Appendix A. Specifications

Technical Specifications . . . . .	A-2
ECG Acquisition . . . . .	A-2
Keyboard . . . . .	A-2
Touchscreen Display . . . . .	A-2
Display Accuracy . . . . .	A-2
Patient Interface Module . . . . .	A-2
Patient Interface Module Signal Acquisition . . . . .	A-2
Signal Processing/Acquisition . . . . .	A-2
Auto Frequency Response . . . . .	A-3
Rhythm Frequency Response . . . . .	A-3
Minimum Amplitude or Value of Patient Physiological Signal . . . . .	A-3
Filters . . . . .	A-3
Printer . . . . .	A-3
Report Formats . . . . .	A-3
Battery Operation . . . . .	A-4
Network Connection . . . . .	A-5
FAX Capability (optional) . . . . .	A-5
Modem (optional for USA and Canada) . . . . .	A-5
Barcode Reader (optional) . . . . .	A-5
Magnetic Card Reader (optional) . . . . .	A-5
Smart Card Reader (optional) . . . . .	A-5
ECG Storage . . . . .	A-5
Orders . . . . .	A-6
ECG File Formats . . . . .	A-6
Power and Environment . . . . .	A-6
Environmental Operating Conditions . . . . .	A-6
Environmental Storage Conditions . . . . .	A-7
Cardiograph Dimensions . . . . .	A-7
Cardiograph Weight . . . . .	A-7
Cardiograph Shipping Container Weight . . . . .	A-7
Safety and Performance . . . . .	A-7
Classification (IEC 60601-1) . . . . .	A-8
Electromagnetic Compatibility (EMC) . . . . .	A-8
Reducing Electromagnetic Interference . . . . .	A-9
Wireless LAN Card Specifications . . . . .	A-14





# Introduction

This *PageWriter TC 70 Service Manual* provides the information you need to successfully service the PageWriter TC 70.

This *Service Manual* includes information on:

- Maintenance procedures
- Troubleshooting procedures and diagnostic tests
- Performance verification and safety testing
- Ordering parts and supplies
- Software Installation
- Cart replacement kits and procedures
- Theory of operation
- Specifications

Before servicing the PageWriter TC 70 cardiographs, review the *PageWriter TC70 Cardiograph Instructions for Use* located on the User Documentation CD shipped with the cardiograph, or download the file from the Philips InCenter site ([incenter.medical.philips.com](http://incenter.medical.philips.com)). This service manual assumes you are familiar with the controls, basic cardiograph operations, and capabilities of the device as described in these documents.

This chapter provides information on:

Who Should Use this Manual . . . . .	1-3
Using the Philips InCenter Site . . . . .	1-4
About Adobe Acrobat Versions. . . . .	1-4
Safety Summary. . . . .	1-5
Symbols Marked on the Cardiograph . . . . .	1-5
Safety Symbols Marked on the Cardiograph Packaging. . . . .	1-7
Safety and Regulatory Symbols Marked on the Cart . . . . .	1-8
Safety and Regulatory Symbols Marked on the AC Power Adapter. . . . .	1-9
Important Patient and Safety Information . . . . .	1-10
Accessories and Supplies . . . . .	1-10
AC Power Adapter and AC Power Cord. . . . .	1-11
Analog ECG Output Signal Port. . . . .	1-12
Batteries. . . . .	1-12
Cart . . . . .	1-12
Defibrillation . . . . .	1-12

Diagrams . . . . .	1-12
Display Accuracy . . . . .	1-13
ECG Interpretation . . . . .	1-13
Electrodes . . . . .	1-13
Faxed ECGs. . . . .	1-13
General Cardiograph Use . . . . .	1-13
IEC 60601-2-51. . . . .	1-13
Lead Wires. . . . .	1-14
Main Waveform Display Screen . . . . .	1-14
Modem Card and Fax Feature. . . . .	1-14
Pacemaker . . . . .	1-14
Patient Data Cable. . . . .	1-14
Patient Interface Module (PIM) . . . . .	1-15
Printer . . . . .	1-15
Servicing the Cardiograph. . . . .	1-15
Software . . . . .	1-15
Touch Screen . . . . .	1-15
USB Memory Stick . . . . .	1-16
PageWriter TC70 Cardiograph Components . . . . .	1-16
Patient Interface Module (PIM). . . . .	1-19
Installing the Batteries . . . . .	1-20
Charging the Batteries . . . . .	1-22
Calibrating the Batteries . . . . .	1-23
Battery Power Indicator. . . . .	1-23
Using the Wireless LAN Card . . . . .	1-24
Using the Modem Module . . . . .	1-25
Using the USB Memory Stick . . . . .	1-25
Using the Barcode Reader . . . . .	1-27
Using the Keyboard Shortcuts . . . . .	1-27

## Who Should Use this Manual

This manual is intended for users who handle preventive maintenance, periodic operational checks, and basic troubleshooting for PageWriter TC 70 cardiographs.

Before attempting to service the cardiographs, you must review the following documentation and training materials:

- *PageWriter TC70 Cardiograph Instructions for Use*
- *This Service Manual*

This *PageWriter TC 70 Cardiograph Service Manual* is intended to assist users in the safe and effective use of the product.

Before attempting to operate this product, read this *Service Manual*, and note and strictly observe all Warning and Cautions as described in this document.

Pay special attention to all of the safety information provided in the Safety Summary section.

The following conventions are used in this document.

---

**WARNING** Warning statements describe conditions or actions that may result in a potentially serious outcome, adverse event, or a safety hazard. Failure to follow a Warning may result in death or serious injury to the user or to the patient.

---

---

**CAUTION** Caution statements describe when special care is necessary for the safe and effective use of the product. Failure to follow a caution may result in minor to moderate personal injury or damage to the product or other property, a remote risk of more serious injury, or may cause environmental pollution.

---

**NOTE** Notes contain additional important information about a topic.

**TIP** A Tip contains suggested information on using a particular feature.

Menu items and button names appear in bold no-serif font. Example: Touch the **Config** button.

Internal software components or file directories appear in regular no-serif font. Example: ECGs are stored to the RubyArchiveInternal directory.

## Using the Philips InCenter Site

The Philips InCenter site provides frequent updates to all Philips Cardiac Systems product documentation and product software, including the PageWriter TC 70 cardiograph.

The Philips InCenter site requires an active registration and password. To register, go to the InCenter site at: [incenter.medical.philips.com](http://incenter.medical.philips.com) and click on the **Need help?** link on the main page. On the following page, click the **Click here for account registration** link located on the right side of the page. The Cardiac Systems InCenter Registration page appears. Complete all of the information fields on the page to receive a login and password for the InCenter site.

Registration for the InCenter site requires the serial number(s) for all PageWriter TC 70 cardiographs in active use at your facility. The serial number is found on the product identification label. The product identification label is located on the rear panel of the cardiograph, next to the AC power cord connector.

### About Adobe Acrobat Versions

Adobe Acrobat Reader version 8.0 must be installed on the PC that is used to access the Philips InCenter site. Previous versions of Acrobat Reader are not compatible with the Philips InCenter site, and attempting to access InCenter with a previous version of Acrobat Reader will result in error messages when opening documents. Uninstall all previous versions of Acrobat Reader, and then proceed for a free install of Acrobat Reader 8.0 at: [www.adobe.com](http://www.adobe.com).

Any version of Adobe Acrobat Professional or Acrobat Elements are also not compatible with the Philips InCenter site, and error messages will appear when opening documents with these applications. Acrobat Reader 8.0 must be installed in addition to Acrobat Professional or Acrobat Elements.









Follow this procedure when accessing documents on the Philips InCenter site.

#### To access documents on the Philips InCenter site:







- 1 Exit Acrobat Professional or Acrobat Elements (if open).
- 2 Start Acrobat Reader 8.0.
- 3 Open Internet Explorer, and go to the Philips InCenter site. Keep Acrobat Reader 8.0 open the entire time while accessing the InCenter site.

# Safety Summary







## Symbols Marked on the Cardiograph

Symbol	Name	Description
	Attention; read the <i>Instructions for Use</i>	See the <i>PageWriter TC70 Cardiograph Instructions for Use</i> .
	Type CF	ECG physio isolation is type CF, defibrillator proof. Suitable for all patient applications including direct cardiac application. System is in continuous operation.
	Direct current	Indicates that the equipment is suitable for direct current only.
	Disposal	Dispose of in accordance with the requirements of your country.
	ECG output signal	The connector near this symbol provides access to an analog ECG signal that can be used as a synchronization signal for external devices, such as an imaging device. This analog ECG signal is not diagnostic quality and should not be used for ECG analysis purposes.
	Local Area Network (LAN) Connector	Connect the Ethernet RJ45 LAN cable to the connector directly beneath this symbol to establish LAN connectivity.
	Modem Connector	Connect an analog phone line to the connector directly beneath this symbol.
	Attention; read the <i>Instructions for Use</i>	See the <i>PageWriter TC70 Cardiograph Instructions for Use</i> .

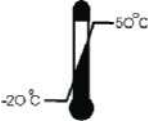
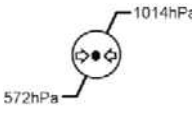
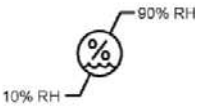



## Symbols Marked on the Cardiograph

Symbol	Name	Description
	Patient Interface Module (PIM) Connector	Connect the PIM patient data cable to the connector located directly beneath this symbol.
	PCMCIA icon	Insert the wireless LAN card into the slot located directly beneath this symbol.
	PS/2 Connector	Connect the Magnetic Card Reader or Barcode Reader to the connector located directly beneath this symbol.
	Option Number	The number next to this symbol is the serial number of the cardiograph.
	Standby	Pressing the button with this symbol on it puts the cardiograph into Standby (power saving mode).
	USB Connector	The connector near this symbol is used with a USB device.
	Non-ionizing electromagnetic radiation	Interference may occur in the vicinity of equipment marked with this symbol.

### Safety Symbols Marked on the Cardiograph Packaging



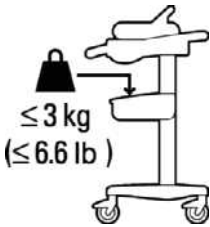

Symbol	Description
	Keep dry.
	Ambient temperature range of -20 °C (-4° F) to 50 °C (122° F) (non-condensing) for transport and storage.
	Atmospheric pressure range of 4572 meters (15,000 feet), 572 hPa above sea level for transport and storage.
	Relative humidity range of 10% to 90% (non-condensing) for transport and storage.
	Made from recycled materials.
	Fragile.
	Lithium ion battery. Do not dispose of in trash. Follow local regulations for disposing of as small chemical waste.
	This product consists of devices that may contain mercury, which must be recycled or disposed of in accordance with local, state, or federal laws. (Within this system, the backlight lamps in the monitor display contain mercury.)
	Dispose of in accordance with the requirements of your country.

## Safety and Regulatory Symbols Marked on the Cart

Symbol	Name	Description
	Cart Transport	Do not transport the cart with the drawer open.
	Cart Drawer Weight Limit	Do not place more than 3 kilograms or 6.6 pounds of weight into the cart drawer.
	Cart Storage Bin Weight Limit	Do not place more than 3 kilograms or 6.6 pounds of weight into the cart storage bin.
 <p>100-240 V~ 50/60 Hz 1.4-0.7 A</p>	AC power connector input	Indicates the location of the cardiograph AC power connector.



## Safety and Regulatory Symbols Marked on the AC Power Adapter

Symbol	Name	Description
	No serviceable parts inside	There are no serviceable parts inside the AC adapter. Do not open the AC adapter case.
	Indoor, dry location use only	The AC adapter is only intended for indoor use in a dry location.
	Attention; read the <i>Instructions for Use</i>	See the <i>PageWriter TC70 Cardiograph Instructions for Use</i> for information on the AC power adapter.
	AC adapter disposal	Dispose of in accordance with the requirements of your country.

## Important Patient and Safety Information

The PageWriter TC70 cardiograph isolates all connections to the patient from electrical ground and all other conductive circuits in the cardiograph. This reduces the possibility of hazardous currents passing from the cardiograph through the patient's heart to ground.

---

**WARNING** Failure to follow these warnings could affect both patient and operator safety.

---

### Accessories and Supplies

---

**WARNING** Always clean and disinfect reusable electrodes before patient use. Failure to properly clean and disinfect reusable electrodes before patient use may cause infectious materials to be transferred between patients.

---

---

**WARNING** The Welsh bulb electrodes (available as an accessory for the cardiograph) do not meet the requirements of IEC 60601-2-25 for defibrillation recovery time, and cannot be reliably used for patient diagnosis immediately following defibrillation.

---

---

**WARNING** When using additional peripheral equipment powered from an electrical source other than the cardiograph, the combination is considered to be a medical system. It is the responsibility of the operator to comply with IEC 60601-1-1 and test the medical system according to the requirements. For additional information contact Philips Medical Systems.

---

---

**WARNING** Do not use non-medical peripherals within 6 feet of a patient unless the non-medical peripherals receive power from the cardiograph or from an isolation transformer that meets medical safety standards.

---

---

**CAUTION** The Welsh bulb electrodes contain natural rubber latex which may cause allergic reactions.

---

- When using additional peripheral equipment powered by an electrical source other than the cardiograph, the combination of
- Using accessories, peripherals, or cables that are not supplied with the cardiograph or that are not recommended by Philips Medical Systems can result in increased emissions or decreased immunity of the cardiograph.
- Only use Philips Medical Systems replacement parts and supplies with the cardiograph. The use of non-approved replacement parts and supplies with the cardiograph is strictly prohibited. Cardiograph safety and performance are not guaranteed when non-approved replacement parts and supplies are used with the cardiograph.

- Connect other equipment in accordance with IEC 60601-1-1 Medical Electrical Systems Standard or IEC 60601-1: 2005 (3rd Edition) Medical Electrical Equipment Standard Clause 16 Medical Electrical Systems.
- When connecting the cardiograph to other AC powered equipment, only connect equipment approved to IEC 60601-1 Medical Electrical Equipment or IEC 60950-1 Information Technology Equipment.
- Only use patient electrodes that are approved by Philips Medical Systems. The use of non-approved patient electrodes may degrade cardiograph performance.
- To prevent burns to the patient, remove all ECG electrodes and lead wires prior to the use of high frequency surgical equipment (including electrosurgical equipment and some respiration transducers).
- The use of equipment that applies high frequency voltages to the patient (including electrosurgical equipment and some respiration transducers) is not supported and may produce undesired results.

## AC Power Adapter and AC Power Cord

---

**CAUTION** The power supply could feel warm to the touch.

---

- The PageWriter TC70 cardiograph external power supply, part number 453564094411 is designed with a three wire supply system. The ground only serves a functional purpose for EMC and not protective earth for electrical safety. Use of an appropriate three-wire power cord is necessary to provide proper EMC operation.
- Only use the AC power adapter designed to be used with the PageWriter TC70 cardiograph, part number 453564094411, in order to ensure continued compliance with the requirements of IEC 60601-1.
- Only use the external power supply with part number 453564094411 with the PageWriter TC70 cardiograph to prevent electrical safety hazards. The use of any other power supply is not approved by Philips Medical Systems.
- To disconnect the cardiograph from AC power, unplug the cardiograph AC power cord from the mains power supply.
- This equipment complies with the earth leakage current limits as specified in UL 60601-1:2003 Medical Electrical Equipment - General Requirements for Safety, only when connected to a 120 Volt mains power supply.
- Use only grounded power cords (three-wire power cords with grounded plugs) and grounded electrical outlets. **Never** adapt a grounded plug to fit an ungrounded outlet by removing the ground prong or ground clip.
- Periodically inspect the patient data cable, lead wires, and AC power cord for any worn or cracked insulation. Ensure that no exposed wires are visible on the AC power cord.

- Only use the Philips Medical Systems AC power supply (part number 453564094411) supplied with the cardiograph. Use of any other power supply has not been verified and may lead to operator or patient harm, including electrical shock. Periodically inspect the AC power cord and AC power connector to ensure that both are in a safe and operable condition. If the AC power cord or AC power connector is not in a safe or operable condition, operate the cardiograph on battery power and contact Philips Medical Systems for service.

## Analog ECG Output Signal Port

- Do not use the analog ECG output signal port (not supported on cardiograph) for diagnostic purposes and do not use this signal for critical synchronization timing.
- Do not connect any equipment to the cardiograph analog ECG output signal port that does not meet medical safety requirements and that has not been evaluated by local safety personnel.

## Batteries

---

**CAUTION** When removing the batteries from the cardiograph, the batteries could feel warm to the touch.

---

- The PageWriter TC70 cardiograph is designed to be operated with two batteries installed, and the battery operational time listed in this *Instructions for Use* is based upon cardiograph operation with both batteries installed. Operation with a single battery is not supported or recommended as it will shorten operational time and decrease overall battery life.
- Only use the batteries designed to be used with the PageWriter TC70 cardiograph, part number 989803144631, in order to ensure continued compliance with the requirements of IEC 60601-1.

## Cart

- Ensure that the cardiograph is securely attached to the cardiograph cart before use.

## Defibrillation

- Do not touch the patient, patient data cable, or cardiograph during defibrillation. Death or injury may occur from the electrical shock delivered by the defibrillator.

## Diagrams

- Upon customer request, Philips Medical Systems will make available circuit diagrams, component part lists, descriptions, calibration instructions and other technical information.

## Display Accuracy

- The accuracy of the ECG signals are within +/- 5% (or +/- 40 uV whichever is greater), over a range of 0 to 5 mV, in the presence of differential and common mode DC offset voltages of +/- 300 mV. The cardiograph performance is tested to comply with the accuracy requirements over the dynamic ranges and frequency ranges specified in the IEC 60601-2-51 and AAMI EC-11 standards.
- For additional details regarding accuracy and precision, refer to the *Physician's Guide* and the Manufacturer's Disclosure Statement.

## ECG Interpretation

---

**CAUTION** Always enter accurate patient information (including age and gender) if using the Philips ECG Algorithm for ECG interpretation.

---

## Electrodes

- Philips recommends the use of disposable electrodes at all times for all patient applications. Choose either adult or pediatric disposable electrodes based on the age and size of the patient. See “Disposable and Reusable Electrodes” on page 5-8 for information on ordering disposable electrodes.

## Faxed ECGs

---

**CAUTION** No guarantee is made as to the suitability of a faxed ECG for any particular purpose, due to the variability inherent in fax technology.

---

## General Cardiograph Use

- Do not use this cardiograph near flammable anesthetics. It is not intended for use in explosive environments or in operating rooms. The disconnection or connection of AC power, or electrostatic discharge (ESD) may result in an electrical spark.
- The cardiograph may generate electromagnetic interference (EMI) that may cause nearby equipment to fail.
- Connecting multiple cardiographs to the same patient may pose a safety hazard due to the summation of leakage currents. Any combination of instruments should be evaluated by local safety personnel before being put into service.

## IEC 60601-2-51

- For information on the standard IEC 60601-2-51, please go to the Philips InCenter web site ([incenter.medical.philips.com](http://incenter.medical.philips.com)).

## Lead Wires

---

**WARNING** Electrical shock hazard. Do not touch accessible connector pins and the patient simultaneously.

---

- Ensure that the electrodes or lead wires do not come in contact with any other conductive materials (including earth-grounded materials) especially when connecting or disconnecting electrodes to or from a patient.

## Main Waveform Display Screen

- Manual measurements of ECG intervals and magnitudes should be performed on printed ECG reports only. Do not make manual measurements of ECG intervals and magnitudes on the main waveform display screen since these ECG representations are scaled.

## Modem Card and Fax Feature

---

**WARNING** Do not connect the modem card to a phone line when the cardiograph is connected to a patient.

---

- No guarantee is made as to the suitability of a faxed ECG report for any particular purpose, due to the variability inherent in fax technology.

## Pacemaker

- Pace pulses may not be visible on a printed ECG report that uses simultaneous acquisition.

## Patient Data Cable

- Keep the patient data cable away from power cords and any other electrical equipment. Failure to do so can result in AC power line frequency interference on the ECG trace.
- The Philips Medical Systems patient data cable (supplied with cardiograph) is an integral part of the cardiograph safety features. Use of any other patient data cable may compromise defibrillation protection and degrade cardiograph performance.
- Periodically inspect the patient data cable for any cracks or breaks in the cable insulation. If the integrity of the patient data cable is not assured, replace the patient data cable. Contact Philips Medical Systems for further assistance.

## Patient Interface Module (PIM)

- Always put the cardiograph in Standby before replacing the Patient Interface Module (PIM). Do not change the PIM while the cardiograph is in active use.
- If using the optional, 16-lead PIM, always ensure that the leads connected to the Patient Interface Module (PIM) are the same leads that are displayed on the cardiograph screen.

## Printer

- Do not pull on the paper while an ECG report is being printed. This can cause distortion of the waveform and can lead to potential misdiagnosis.

## Servicing the Cardiograph

- Only qualified personnel may service the cardiograph or may open the cardiograph housing to access internal cardiograph components. Do not open any covers on the cardiograph. There are no internal cardiograph components that are serviced by the operator.
- The Philips Medical Systems warranty is applicable only if you use Philips Medical Systems approved accessories and replacement parts. See “Parts and Supplies” on page 5-1 for more information.

## Software

- Only install Philips Medical Systems software on the cardiograph. The installation or use of software not approved by Philips Medical Systems is strictly prohibited and cardiograph safety and performance are not guaranteed.

## Touch Screen

- Do not use sharp objects with the touch screen or apply excessive force to the touch screen. Applying excessive force to the touch screen may result in breaking the touch screen display and can cause sharp, jagged parts to expel to persons nearby.
- Manual measurements of ECG intervals and magnitudes should be performed on printed ECG reports only. Do not make manual measurements of ECG intervals and magnitudes on the touchscreen display since these ECG representations are scaled.

## USB Memory Stick

**CAUTION** Only use the USB memory stick that is available for purchase as an optional accessory from Philips Medical Systems with the PageWriter TC cardiograph.

Do not insert a USB memory stick into the cardiograph, or remove a USB memory stick from the cardiograph when the cardiograph is acquiring ECG data from the patient.

Only use the USB memory stick to transfer data between the cardiograph and a computer. Do not use the USB memory stick with other devices.

- Do not import ECGs into the cardiograph from another cardiograph, or from other devices to the cardiograph using a USB memory stick.

## PageWriter TC70 Cardiograph Components

The following sections include a description of all of the components of the cardiograph, including the connection ports on the cardiograph, the Patient Interface Module (PIM), and optional accessories available with the cardiograph.

**Figure 1-1** Cardiograph (left front view)

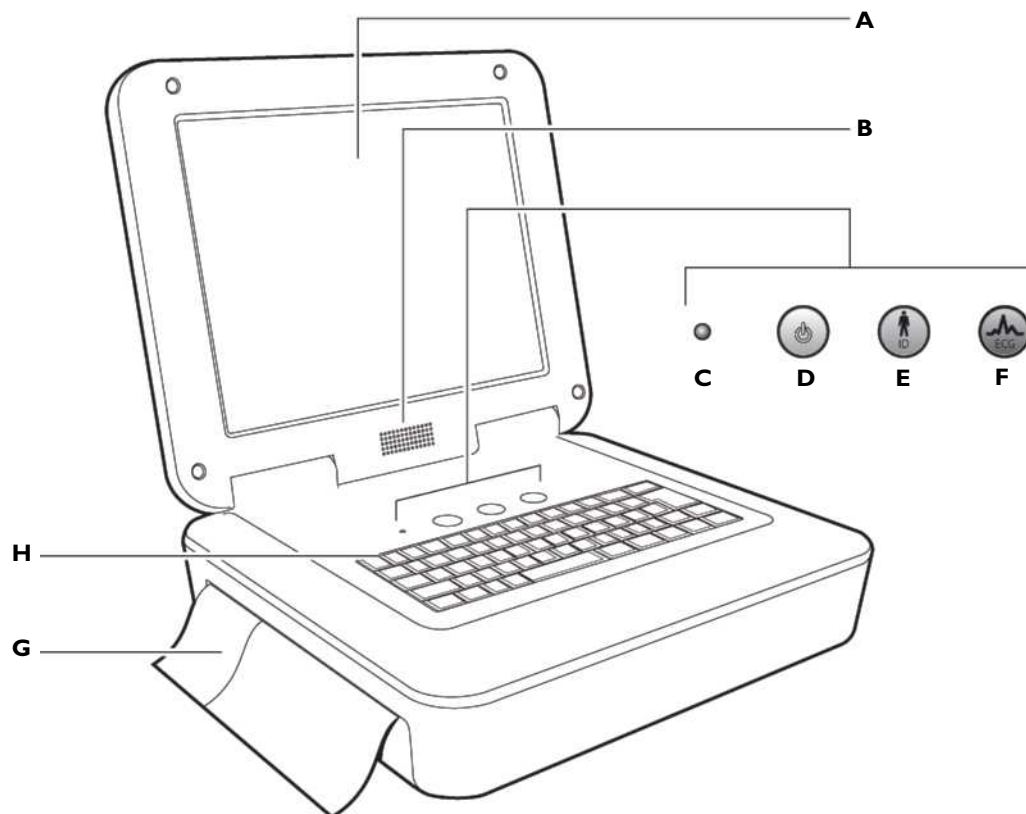

- |                                      |                     |
|--------------------------------------|---------------------|
| <b>A</b> Touch screen                | <b>F</b> ECG button |
| <b>B</b> Audio speaker               | <b>G</b> Paper tray |
| <b>C</b> AC power on indicator light | <b>H</b> Keyboard   |



**D** On/Off button

**E** ID button

**Figure 1-2** Cardiograph (right front view)

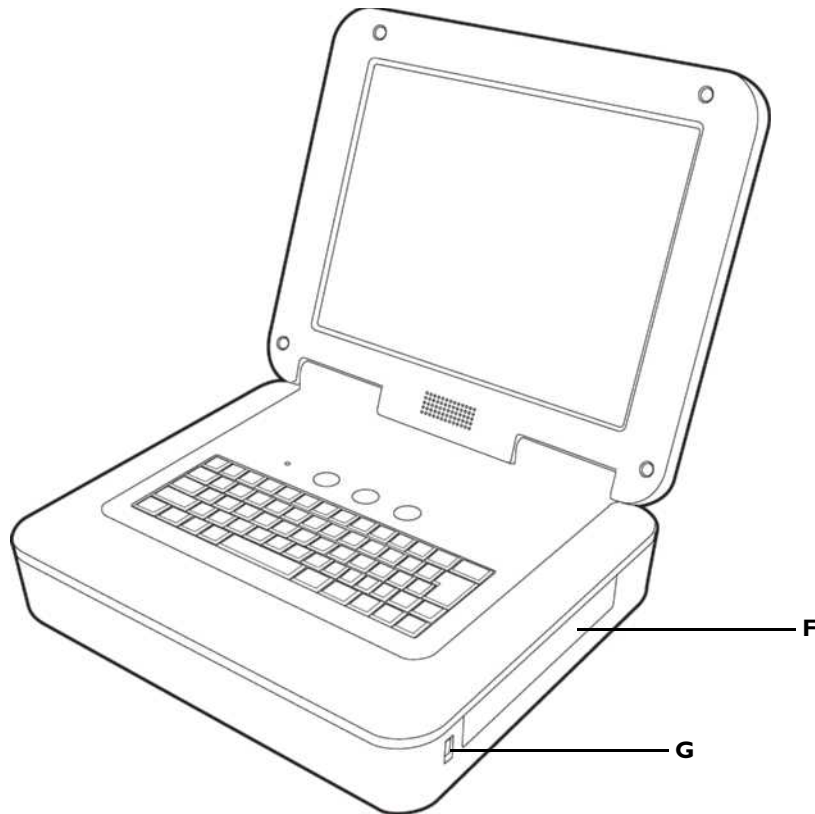

**I** Battery compartment

**J** USB memory stick connector

Figure 1-3 Cardiograph (rear view)

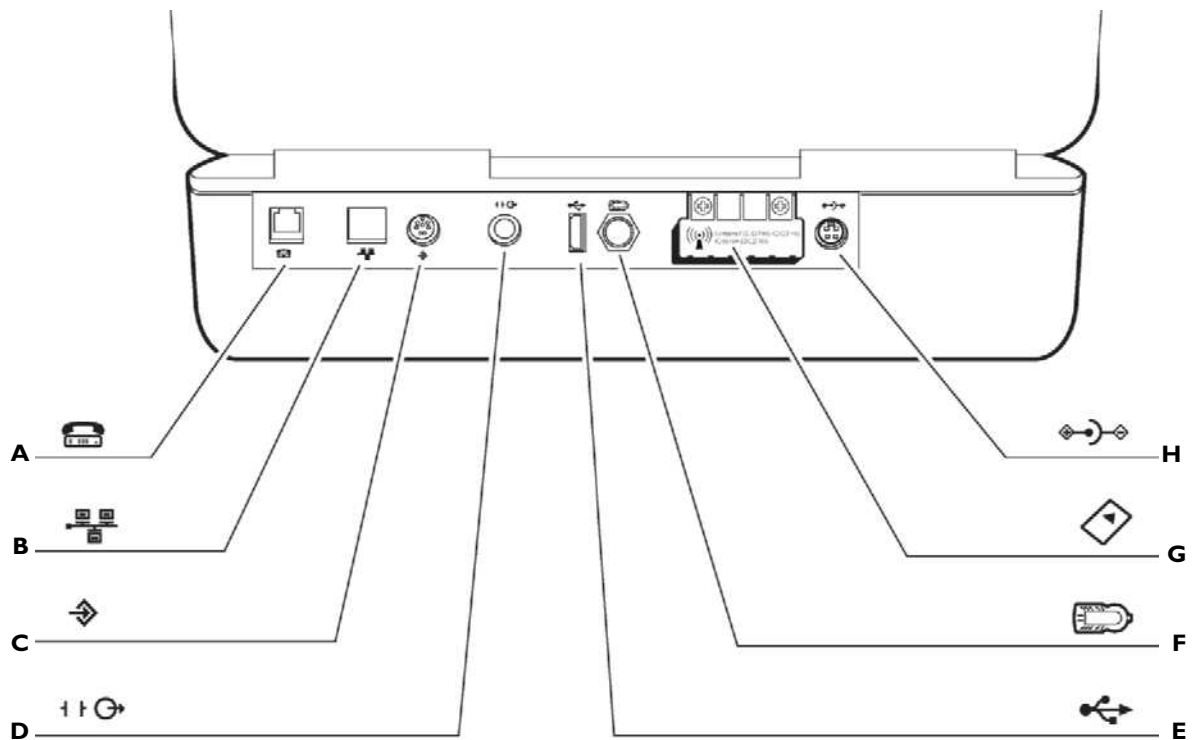

- |   |   |
|---|---|
| <b>A</b> Modem connector                                    | <b>G</b> Wireless LAN card slot (with protective cover installed) |
| <b>B</b> LAN connector                                      | <b>H</b> AC power connector                                       |
| <b>C</b> Barcode reader or magnetic card reader connector   |   |
| <b>D</b> Analog ECG output signal connector (not supported) |   |
| <b>E</b> USB connector                                      |   |
| <b>F</b> PIM connector                                      |   |

---

**WARNING** Do not connect the modem card to a phone line when the cardiograph is connected to a patient.

---



---

**CAUTION** Do not insert a USB memory stick into the cardiograph, or remove a USB memory from the cardiograph when the cardiograph is acquiring ECG data from a patient.

---

## Patient Interface Module (PIM)

The Patient Interface Module (PIM) is a hand-held device that connects to the patient data cable. The PIM is available in a standard 12-lead, or an optional 16-lead model. The PIM is shipped with the patient data cable fully connected to the PIM.

**Figure 1-4 16-lead (left) and 12-lead (right) Patient Interface Module (PIM)**

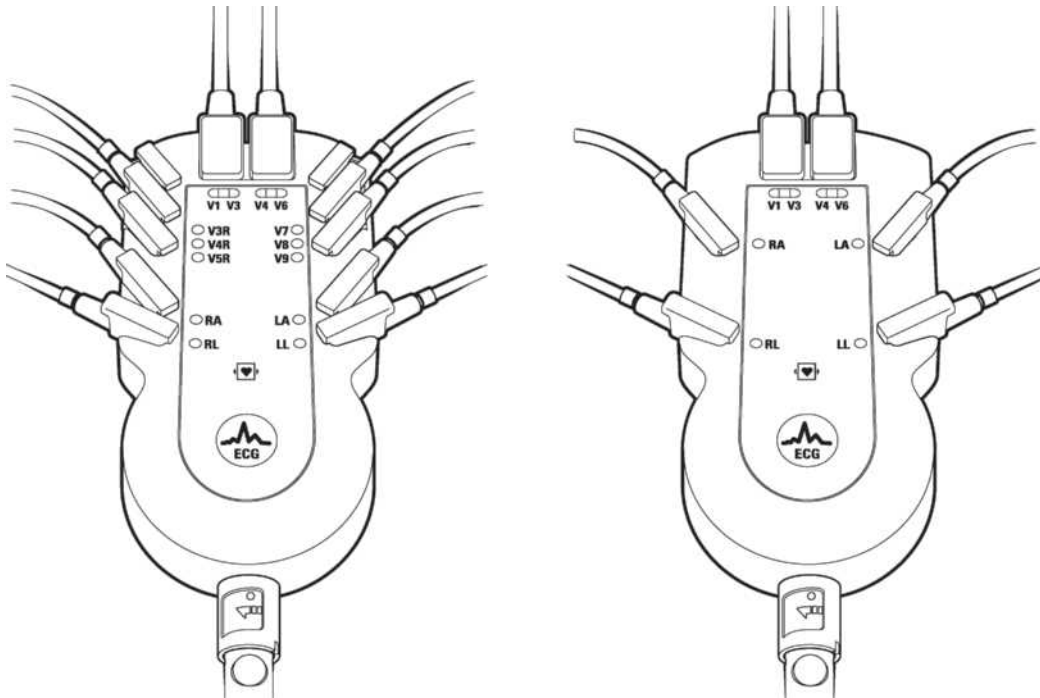

## Installing the Batteries

The cardiograph is shipped with two batteries that are used to power the cardiograph when AC power is not available.

---

**CAUTION** Insert the batteries into the cardiograph before plugging the cardiograph into AC power.

---

### To install the batteries:

- 1 Open the battery door.

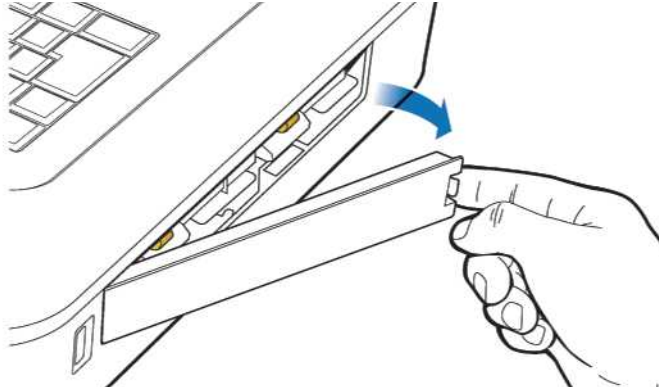

- 2 Locate the two gold pull tabs inside of the battery compartment. Pull the tabs straight out of the battery compartment and ensure that both are pulled taut.

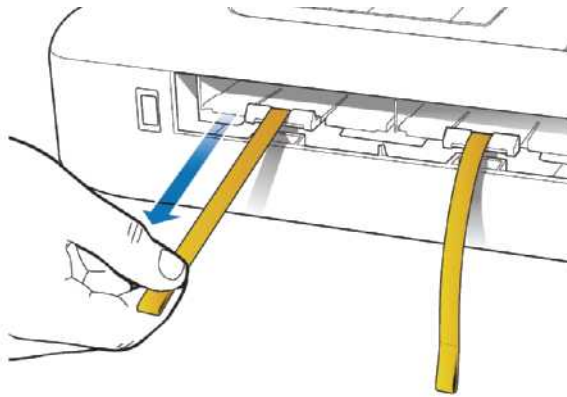

- 3 Insert the battery with the external connector facing the bottom rear of the compartment.

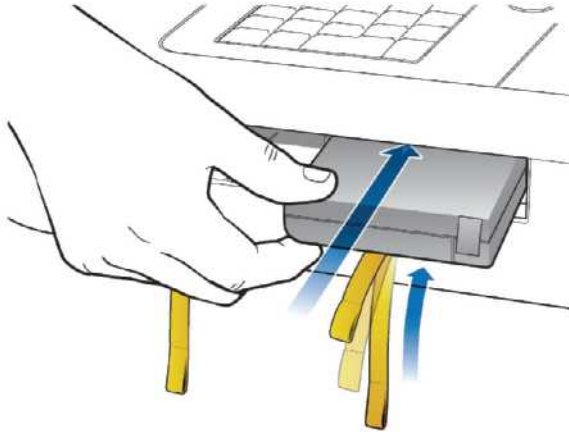

- 4 Ensure that the battery is fully inserted into the slot. The pull tab will insert along with the battery. Insert the second battery following the same procedure.

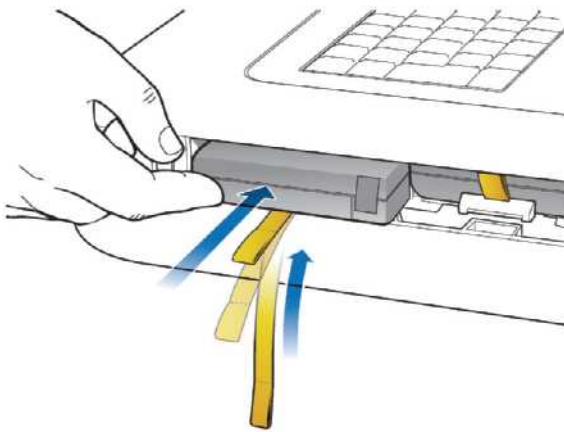

- 5 Reinstall the battery door.

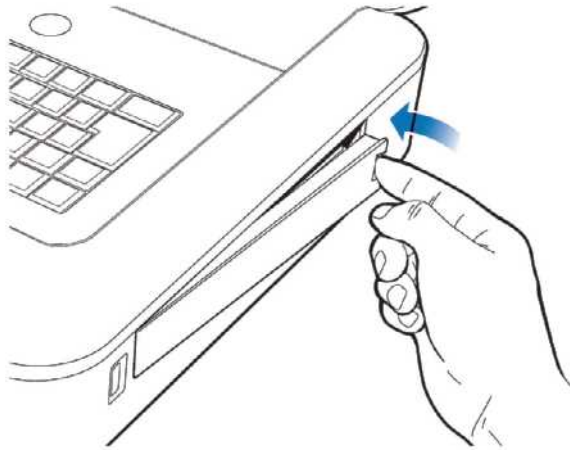

- 6 Connect the AC power cord to the cardiograph. Charge the batteries for five hours before operating the cardiograph on battery power only.

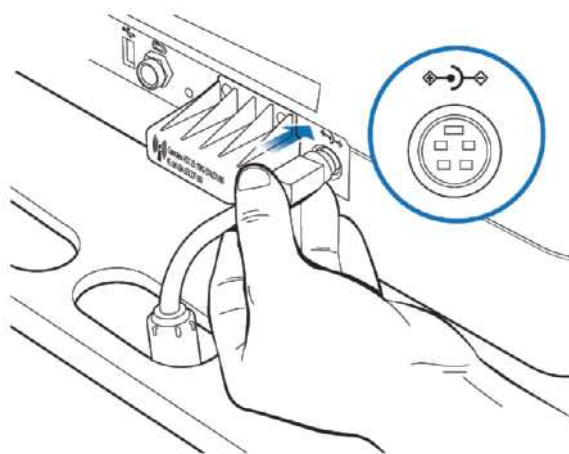

## Charging the Batteries

Charge the batteries for five hours prior to initial use. Plug the cardiograph into AC power whenever possible, and fully charge the batteries. Proper battery maintenance and care, including frequent and full charging of the batteries, will help to prolong battery life.

There are configurable power saving features available on the cardiograph. These features are used to help prolong overall battery life, and to optimize battery power use between battery charges.

---

**CAUTION** When removing the batteries from the cardiograph, the batteries could feel warm to the touch.

---

## Calibrating the Batteries

The batteries may require periodic calibration to ensure the continued accuracy of the battery power and overall battery status information displayed on the cardiograph. For more information on battery calibration, see “Battery Calibration” on page 2-14.

## Battery Power Indicator

The battery power indicator appears on the Status Bar and is always visible. The indicator displays the current battery power level. The cardiograph can operate on AC power while the batteries are charging, but the batteries will charge at a slower rate.

**Figure 1-5 Battery Power Indicator on the Status Bar**



### A Battery level indicator

Double-tap the Battery Power Indicator on the Status Bar to ensure that the batteries are fully charged.

#### To check the battery power level:

- 1 Double-tap on the battery icon on the Status Bar. The Battery Status Information window appears. This window provides detailed information on the status of the cardiograph batteries.



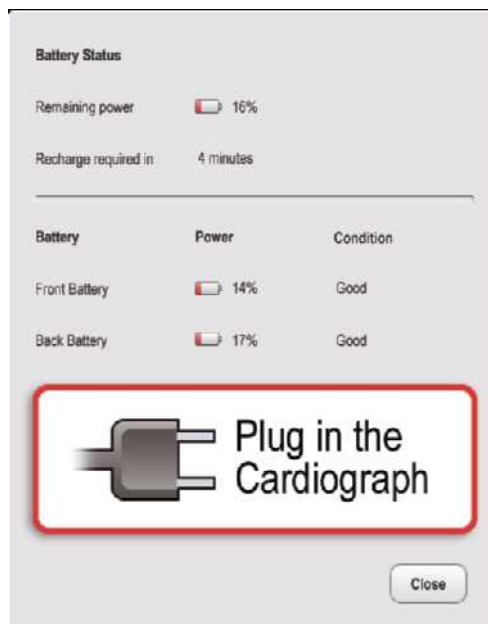

**NOTE** If the **Plug in the Cardiograph** message appears, the cardiograph needs to be plugged into AC power immediately.

**Figure 1-6 Battery Status Information**



- 2 Touch the **Close** button to close the window.

**Table 1-1 Battery Level Indicator Information (icon on Status Bar)**

Battery Level	Icon on Status Indicator
Fully Charged Battery	
75% power capacity	
50% power capacity	
Low Battery Power: <ul style="list-style-type: none"> <li>■ red battery icon appears when power level is between 20-30%</li> <li>■ cardiograph <i>beeps</i> and an error message appears until the unit is plugged into AC power (audio feature may be disabled)</li> <li>■ double-tap the icon to see how many minutes are left of operating battery power</li> </ul>	
No or Dead Battery	

## Using the Wireless LAN Card

The PageWriter TC70 cardiograph supports the Summit Wireless LAN card. The wireless LAN card is used to transfer ECG and order data between the cardiograph and a TraceMaster ECG Management System.

---

**CAUTION** Only use wireless LAN cards with the PageWriter TC70 cardiograph that have been purchased from Philips Medical Systems. The use of non-approved wireless LAN cards with the PageWriter TC70 cardiograph is not tested or supported, and Philips Medical Systems does not guarantee cardiograph operation or wireless LAN connectivity.

---

For information on installing the card and configuring the cardiograph for wireless transmission, see the *PageWriter TC70 Cardiograph Wireless LAN Installation Instructions*. The file is available for download from the Philips InCenter site.



## Using the Modem Module

The modem module is an optional accessory that is used to fax ECGs to a configured receiving fax machine, or is used to transfer ECGs or orders by modem to a TraceMaster ECG Management System. The modem module used either as a fax or as a modem must be configured before initial use with the cardiograph. For information on configuring the modem module to transmit data to a TraceMaster ECG Management System, see the *PageWriter TC70 Cardiograph Network Configuration Guide* available on the User Documentation CD, or the file can be downloaded from the Philips InCenter site.

---

**WARNING** Do not connect the modem module to a phone line when the cardiograph is connected to a patient.

---

## Using the USB Memory Stick

The USB memory stick is an optional accessory that is used to transfer orders to the cardiograph from a computer that has the WebSelect Utility installed, and can also be used to transfer completed ECGs from the cardiograph to a TraceMaster ECG Management System for reconciliation and processing. The USB memory stick can also be used to save custom settings specified on the Setup screens as a *Custom Settings* file. This Custom Settings file can then be transferred to additional cardiographs to help speed up the configuration process.

For information on using the WebSelect Utility, see the *Using OrderVue with PageWriter Cardiographs* guide on the User Documentation CD, or download the file from the Philips InCenter site.

---

**CAUTION** The PageWriter TC70 cardiograph only supports the USB memory stick that is available for purchase as an optional accessory from Philips Medical Systems. Philips does not guarantee that other USB memory sticks are compatible with the PageWriter TC70 cardiograph.

---

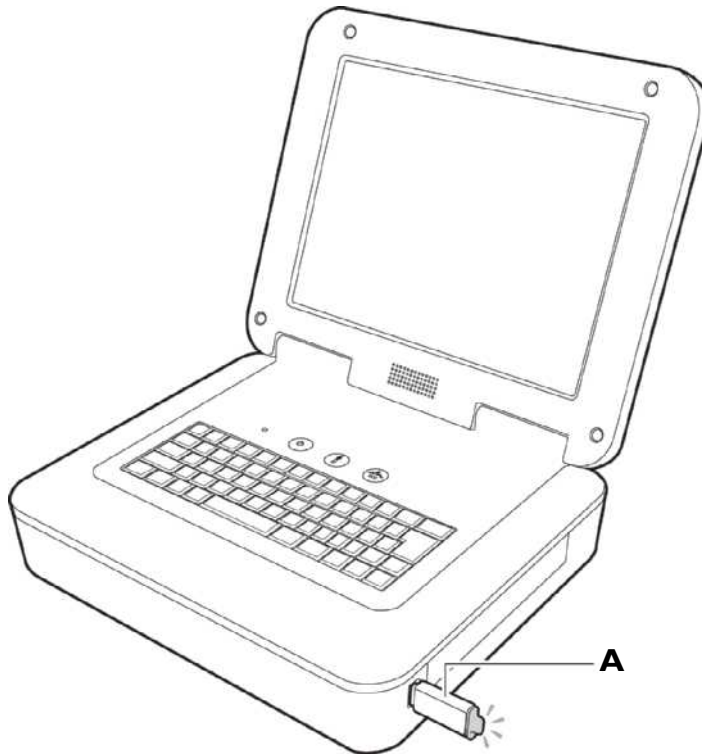
**Figure 1-7** USB memory stick inserted into USB connector

**A** USB memory stick inserted into USB connector (tip illuminates when properly inserted)

The USB memory stick can store a combined total of up to 200 ECGs or orders. Ensure that the USB memory stick is firmly inserted into the USB connector located on the front right side of the cardiograph (next to the battery door). The tip of the USB memory stick illuminates when it is properly inserted into the USB connector.

---

**CAUTION** Do not insert a USB memory stick into the cardiograph, or remove a USB memory from the cardiograph when the cardiograph is acquiring ECG data from a patient.

---

---

**CAUTION** Only use the USB memory stick to transfer data between a PageWriter TC70 cardiograph and a computer. Do not use the memory stick with other devices.

---

## Using the Barcode Reader

The barcode reader is an optional accessory that is used to quickly enter ID information by scanning a barcode.

The barcode reader attaches to the barcode reader connector (↔) on the rear panel of the cardiograph. Attach the barcode reader to the cardiograph before turning on AC power.

**Figure 1-8 The Barcode Reader**

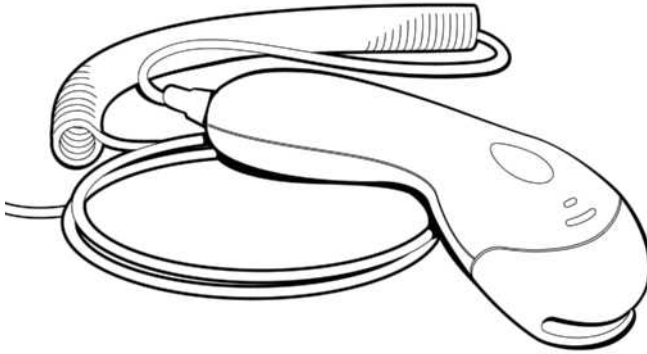

## Using the Keyboard Shortcuts

The following key stroke combinations can be used from any cardiograph screen.

**Table 1-2 Keyboard Shortcuts**

Keyboard Shortcut	Action
<b>Ctrl + Alt + C</b>	Runs the Touch Screen Calibration test. See “Touch Screen Calibration and Test” on page 3-41 for more information.
<b>Ctrl + Alt + P</b>	Saves the current cardiograph screen to a USB memory stick.



---

## Cardiograph Care and Maintenance

The following chapter contains information about basic cardiograph care, and periodic cardiograph maintenance that may be required.

This chapter provides the following information:

Cardiograph and PIM Cleaning . . . . .	2-3
Approved Cleaning Solutions . . . . .	2-3
Patient Data Cable and Lead Wire Cleaning . . . . .	2-4
Approved Cleaning Solutions . . . . .	2-4
Reusable Electrode Cleaning . . . . .	2-5
Cleaning the Print Head . . . . .	2-6
Printer Paper . . . . .	2-7
Tearing Paper . . . . .	2-10
Battery Maintenance and Care . . . . .	2-10
Replacing the Batteries . . . . .	2-11
Battery Calibration . . . . .	2-14
Maintaining the Touch Screen . . . . .	2-16
Touch Screen Calibration . . . . .	2-16
Touch Screen Cleaning . . . . .	2-16
Changing the Date and Time . . . . .	2-17
Cardiograph Overall Sensitivity Test . . . . .	2-18
Before You Begin . . . . .	2-18
Performing the Sensitivity Test . . . . .	2-18
Cardiograph and Accessory Disposal . . . . .	2-19

**Table 2-1 Recommended Frequency of Maintenance Tasks**

<b>Component</b>	<b>Recommended Frequency</b>	<b>Maintenance Task and page number</b>
Cardiograph and Patient Interface Module (PIM) Cleaning	Weekly	“Cardiograph and PIM Cleaning” on page 2-3
Patient Data Cable and Lead Wire Cleaning	Weekly	“Patient Data Cable and Lead Wire Cleaning” on page 2-4
Reusable Electrode Cleaning	After each patient use	“Reusable Electrode Cleaning” on page 2-5
Print Head Cleaning	When necessary due to uneven print quality	“Cleaning the Print Head” on page 2-6
Battery Calibration	When necessary, due to inaccurate battery status information displayed on cardiograph	“Battery Calibration” on page 2-14
Touch screen calibration	When necessary, due to decreased touch screen performance	“Touch Screen Calibration” on page 2-16
Touch screen cleaning	Weekly	“Touch Screen Cleaning” on page 2-16
Cardiograph Overall Sensitivity Test	Yearly	“Cardiograph Overall Sensitivity Test” on page 2-18

## Cardiograph and PIM Cleaning

### To clean the cardiograph and PIM:

- 1 Unplug the AC power cord.
- 2 Ensure that the AC power indicator light (next to power button) is not lit.
- 3 Wipe the external surfaces of the cardiograph and the PIM with a soft cloth dampened in any of the approved cleaning solutions listed below.

---

**CAUTION** When cleaning, avoid the lead wire connectors and patient data cable connectors.

---

### Approved Cleaning Solutions

- Mild soap and water
- Isopropyl alcohol (consisting of 70% solution in water)
- Chlorine bleach (6% sodium hypo chlorite content), 3% solution in water
- Quaternary ammonium compounds (21% quaternary ammonium content), for example, Steris Coverage Plus NPD at a consistency of one half ounce per gallon of water (one part Coverage Plus NPD to 255 parts water)

---

**CAUTION** Do not use strong solvents or abrasive cleaning materials.

Do not spill liquids on the surface of the cardiograph.

Do not use any of the following to clean the cardiograph:

- Acetone
- Iodine-based cleaners
- Phenol-based cleaners
- Ethylene oxide sterilization

The cardiograph or PIM should not be autoclaved, ultrasonically cleaned, or immersed.

---

# Patient Data Cable and Lead Wire Cleaning

## Approved Cleaning Solutions

- Mild soap and water
- Isopropyl alcohol (consisting of 70% solution in water)
- Chlorine bleach (6% sodium hypo chlorite content), 3% solution in water
- Quaternary ammonium compounds (21% quaternary ammonium content), for example, Steris Coverage Plus NPD at a consistency of one half ounce per gallon of water (one part Coverage Plus NPD to 255 parts water)

### To clean the patient data cable and lead wires:

- 1 Dampen a soft cloth with soapy water or with one of the disinfectants or cleaning agents listed in “Approved Cleaning Solutions” (above).
- 2 Wring excess moisture from the cloth before cleaning.

---

**CAUTION Do not:**

- Autoclave the patient data cable or lead wires or use ultrasonic cleaners
  - Immerse
  - Use abrasive materials
  - Wet the connectors
-



## Reusable Electrode Cleaning

Reusable limb clamp and Welsh Bulb electrodes must be cleaned after each use.

---

**WARNING** Always clean and disinfect reusable electrodes before patient use. Failure to properly clean and disinfect reusable electrodes before patient use may cause infectious materials to be transferred between patients.

---

Figure 2-1 Welsh Bulb and Limb Clamp Electrode

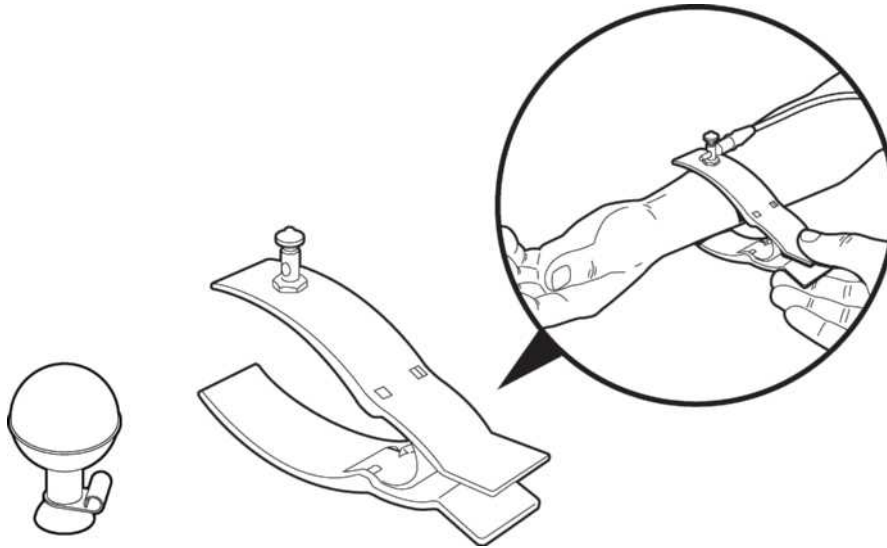

**To clean reusable electrodes:**

- 1 For Welsh Bulb electrodes only: detach the rubber bulb from the metal cup by pulling. Wash the rubber bulb in warm water. Remove all electrolyte gel residue, check inside the rubber bulb to ensure that all residue is removed.
- 2 For all reusable electrodes: dampen a soft cloth with one of the disinfectants or cleaning agents listed below.
  - Cidex Ortho Phthalaldehyde
  - Cetylcide
  - Vesphene 2 Aqueous Phenolic Germicidal Agent

---

**CAUTION Do not:**

- Use isopropyl alcohol
  - Autoclave the reusable electrodes or use ultrasonic cleaners
  - Use abrasive materials
- 

- 3 Wring excess moisture from the cloth before cleaning.
- 4 Dry the bulb and cup of the Welsh Bulb electrode thoroughly before use.

- 5 Store the reusable electrodes away from direct sunlight and excessive heat when not in use.

## Cleaning the Print Head

Clean the print head periodically, as a dirty print head may cause poor or uneven print quality. Clean the print more frequently when printing large volumes of ECGs.

**Figure 2-2** Cleaning the Print Head

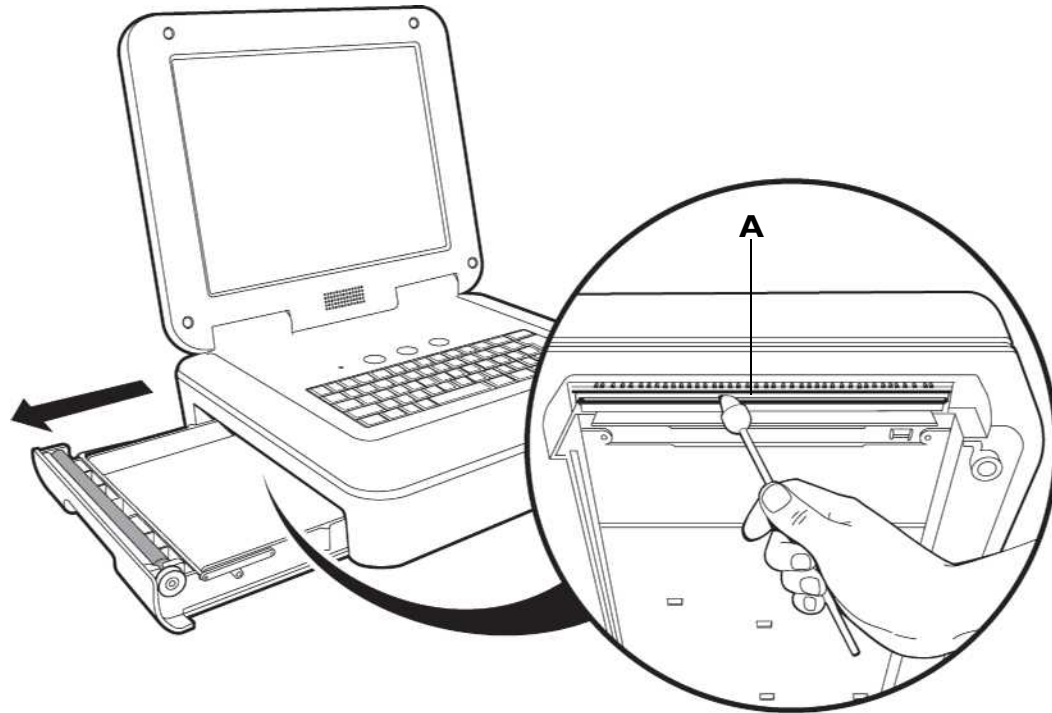

**A** Print head

**To clean the print head:**

- 1 Open the paper drawer (left side of cardiograph).
- 2 Wipe the print head lightly with a foam swab dipped in 90% alcohol.
- 3 Allow the print head to dry.

## Printer Paper

Replace the printer paper when a red stripe appears on the printed ECG report. Only use Philips Medical Systems replacement printer paper. For part ordering information, see “Supplies and Ordering Information” on page 1-33.

### To change the printer paper:

- 1 Open the paper drawer (left side of cardiograph) and remove any remaining sheets. Lift up the paper hold down bar.

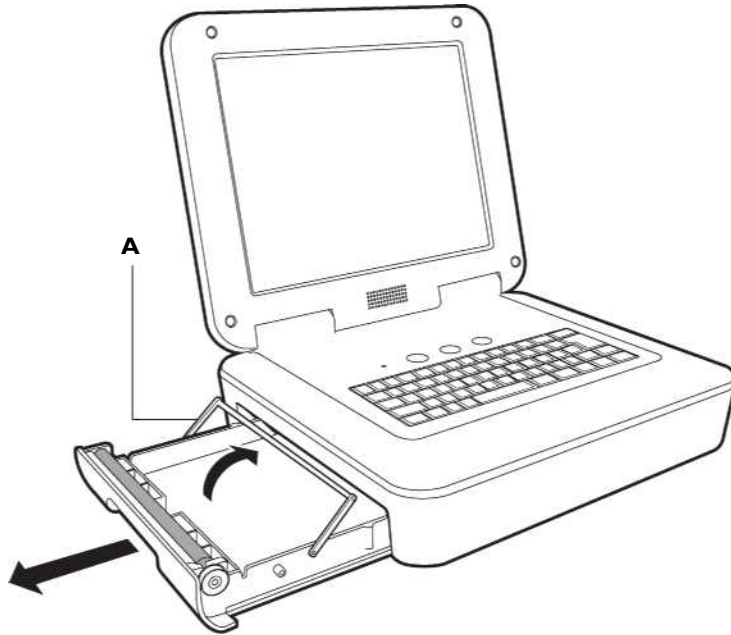

- A** Paper hold down bar
- 2 Insert a new pack of printer paper with the printed side facing up. Make sure that the hole for the paper sensor is positioned as shown below.

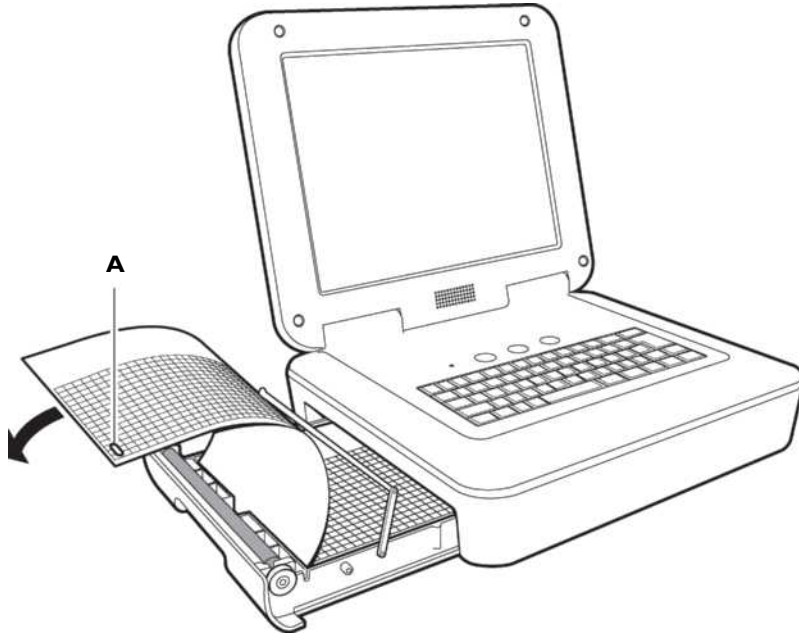

**A** Paper sensor hole

- 3 Drape the first sheet over the roller and place the paper hold down bar on top of the paper.

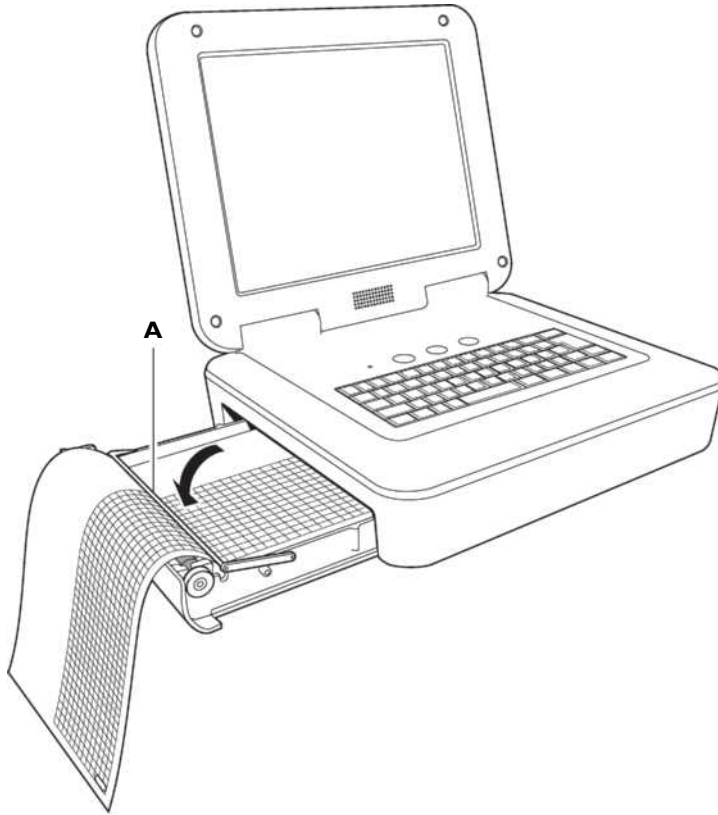

- A** Paper hold down bar
- 4 Close the paper drawer.

## Tearing Paper

Tear off the printer paper as shown.

**Figure 2-3 Tearing Off Printer Paper**

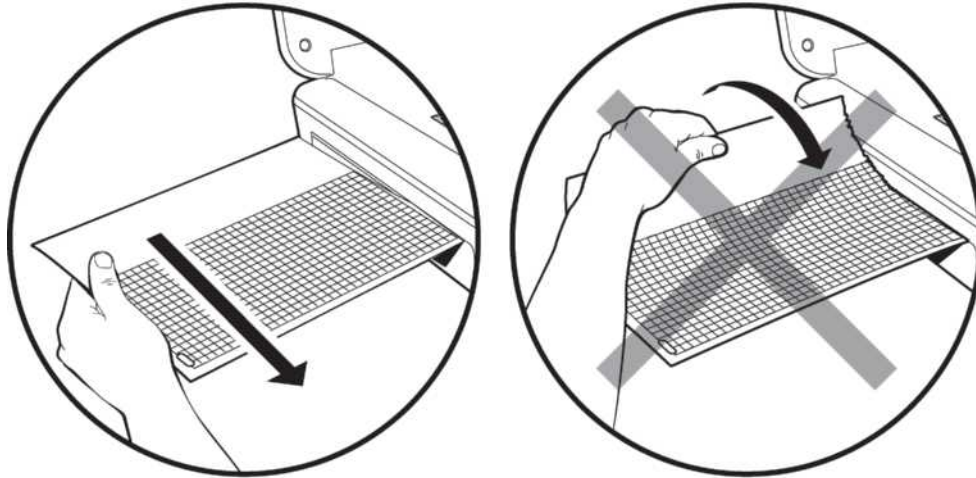

## Battery Maintenance and Care

The cardiograph has two removable lithium ion batteries that supply power to the cardiograph during mobile use, and power the cardiograph printer while it is plugged into AC power.

For optimal battery performance:

- Only use Philips Medical Systems lithium ion batteries (Philips part number 989803160981) with the cardiograph.
- Before initial use, fully charge the batteries for five hours before operating the cardiograph without AC power. Regularly and consistently charging the batteries will prolong battery life.
- Charging, storing, or using the batteries at temperatures above 50 °C (122° F) can damage the batteries and reduce overall battery life.
- Check the battery power indicator on the Status Bar. Tap the battery icon on the Status Bar for information on remaining battery power, see “Battery Power Indicator” on page 1-23.
- Always charge the batteries when the cardiograph is not in use. Plug the cardiograph into AC power. Ensure that the green AC power indicator light on the front of the cardiograph is lit. The batteries will charge while the cardiograph is in use, but will charge at a slower rate.
- Operate the cardiograph, charge the batteries, and store the batteries at a room temperature of 25 °C (77° F) or lower. Exposure to higher temperatures may reduce battery life, damage the batteries, and degrade overall cardiograph performance.

- If the cardiograph will be stored for more than sixty days without use, fully charge the batteries, and then remove AC power from the cardiograph, and remove the batteries from the cardiograph. Store the batteries in a cool, dry location. A set of fully charged batteries stored outside the cardiograph will need to be recharged every sixty days.

## Replacing the Batteries

---

**WARNING** Properly dispose of or recycle depleted batteries according to local regulations. Do not disassemble, puncture, or incinerate the disposed batteries.

---

**WARNING** Carefully follow the instructions for replacing the batteries. Only use batteries with Philips part number 989803160981.

---

**CAUTION** When removing the batteries from the cardiograph, the batteries could feel warm to the touch.

---

How often batteries need to be replaced depends on how well the battery is maintained and how much it is used. If the batteries are fully charged but lose significant power after only a few ECGs, consider replacement. For information on ordering replacement batteries, see “Ordering Options and Upgrades” on page 1-37.

### To install the batteries:

- 1 Unplug the cardiograph from AC power.

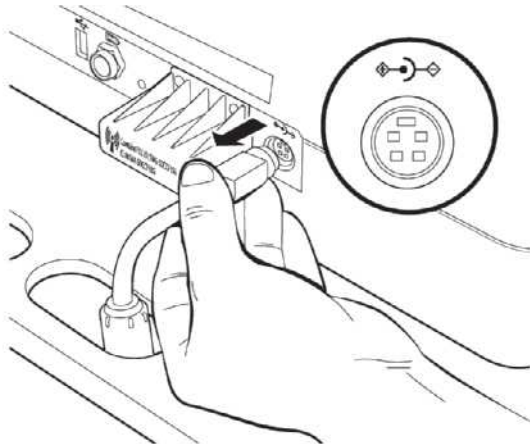

- 2 Open the battery door.

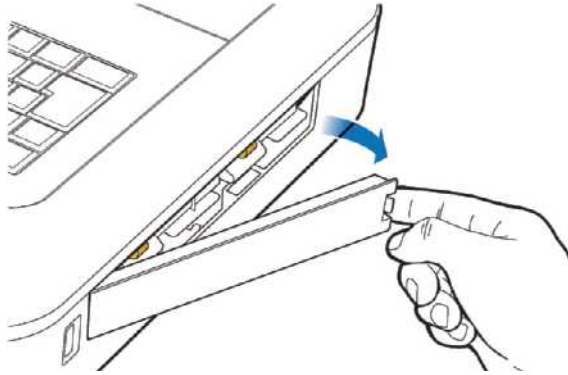

- 3 Remove both batteries from the battery compartment by pulling on the gold straps.

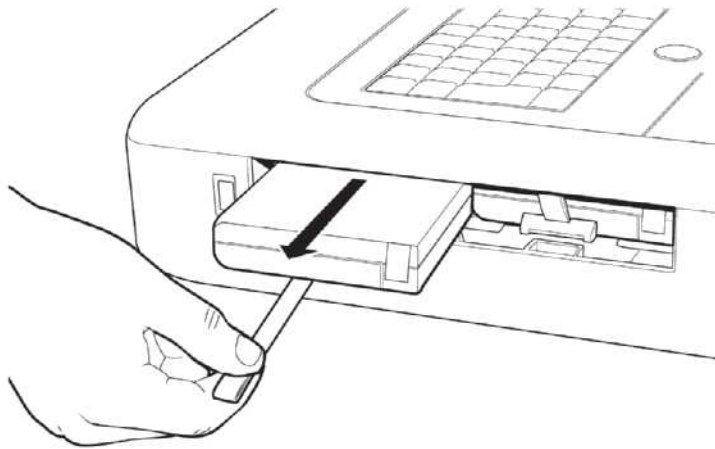

- 4 Insert the battery with the external connector facing the bottom rear of the compartment.

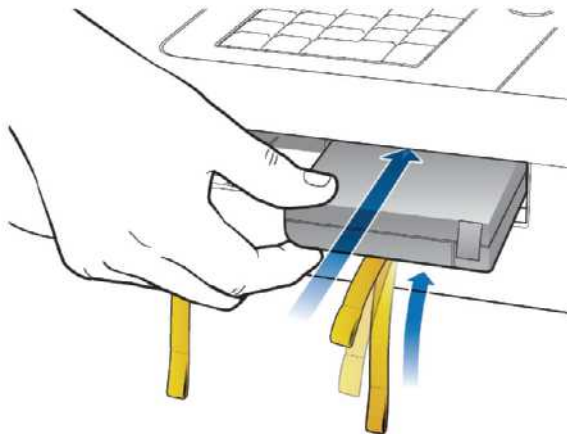



- 5 Ensure that the battery is fully inserted into the slot. The pull tab will insert along with the battery. Insert the second battery following the same procedure.

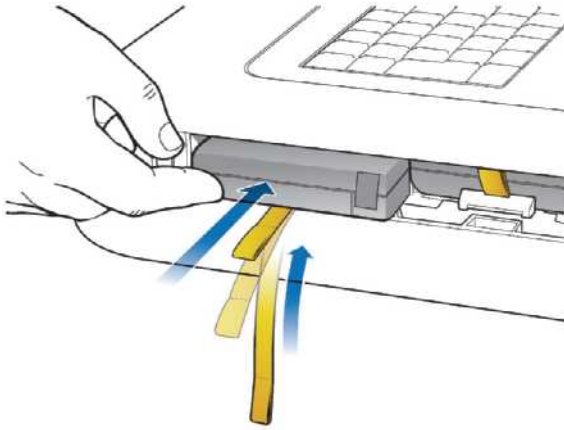

- 6 Reinstall the battery door.

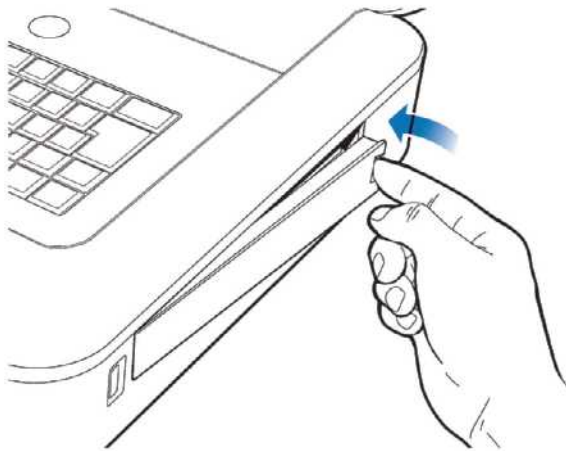

- 7 Connect the AC power cord to the cardiograph. Charge the batteries for five hours before operating the cardiograph on battery power only.

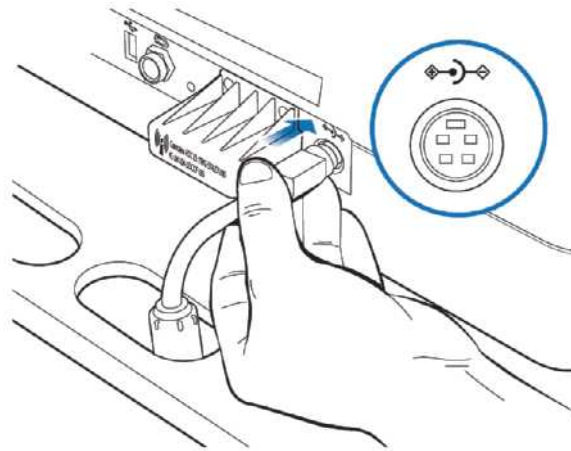

## Battery Calibration

Battery calibration may be necessary in order to enhance the accuracy of the battery level indicator that displays on the Status Bar. If the accuracy of this indicator is affected, the other battery indicators included on the Battery Status window that is opened by tapping the battery icon on the Status Bar may also be less accurate.

**Figure 2-4 Battery Level Indicator on Status Bar**



The **Estimated Remaining Runtime** and Power (bar indicators) may not be accurate. The recommended intervals for battery calibration are dependent upon factors in your clinical use model. When the battery power indicators are not functioning so that they are useful in your daily work environment, Philips recommends calibrating the batteries following the procedure described in this section.

The battery calibration procedure requires that the cardiograph be taken out of active use for up to 8 hours. If this is not practical for your specific clinical environment, an optional battery charger/calibrator s available for purchase from Philips Medical Systems, using part number 989803162021. For more information on ordering the optional battery charger and calibrator, see “Supplies and Ordering Information” on page 1-33.

**To calibrate the batteries on the cardiograph:**

- 1 Attach the AC power cord to the cardiograph. Ensure that the AC power supply is connected to a grounded electrical outlet and that the cardiograph is receiving AC power. Check that the AC power indicator light (located next to the power button) is lit.
- 2 Fully charge the batteries.
- 3 To ensure that the batteries are fully charged, view the **Charge Current** field in the Service Utility. Touch the **Setup** button on the toolbar. Select the Service Utility from the Setup main menu.

**NOTE**

Accessing the Service Utility may require entering a password. If a password is lost and cannot be retrieved, contact the Philips Response Center for assistance.

- 4 From the Service Utility screen, ensure that the **About the Cardiograph** button is selected (top of screen). A selected button is highlighted in blue.
- 5 Underneath the **Battery Status** column (middle of screen), check that the **Charge Current** field for both batteries display **0 mA**, ensuring that both batteries are fully charged.
- 6 Touch the **Print** button (top of screen) to print out a report of the cardiograph settings displayed on this screen.
- 7 Touch the **Exit** button (lower right hand corner of screen). Touch the **Exit** button again on the Setup main menu.
- 8 Once the Main screen appears, touch the **ID** button to open the ID entry screen. Ensure that the ID screen remains open.
- 9 Unplug the cardiograph from AC power. Ensure that the AC power indicator light (located next to the power button) is *not* lit.
- 10 Keep the ID screen displayed and allow the batteries to deplete of all battery power. This process will take approximately 8 hours to complete. When the batteries are depleted of all power, the screen is black and the cardiograph cannot be returned to active use by touching the power button.
- 11 Once the batteries are fully depleted, reconnect the cardiograph to AC power. Press the power on the cardiograph to return it to active use.
- 12 On the Main screen, touch the **Setup** button.
- 13 Select the Service Utility from the Setup main menu.
- 14 From the Service Utility screen, ensure that the **About the Cardiograph** button is selected (top of screen). A selected button is highlighted in blue.
- 15 Underneath the **Battery Status** column, check the **Expected Max Error (%)** and **Full Capacity (mAh)** values as viewed on the screen are different than the values printed on the report generated from the Service Utility screen. If the values are different, the battery calibration procedure is complete.

**NOTE** If the **Expected Max Error (%)** field has not been reset to 2%, another calibration procedure may be necessary. The max error value may not change if the full charge capacity has been decreased by more than 256 mAh or increased by more than 512 mAh. If this occurs, another calibration procedure is recommended as soon as it is convenient to further improve the accuracy of displayed battery status information. For batteries with more than 8% of error, the maximum error will remain unchanged if a limited calibration cycle occurs.

## Maintaining the Touch Screen

The touch screen may require occasional maintenance, including calibration and cleaning.

### Touch Screen Calibration

The touch screen may be calibrated at any time. Calibration is recommended if it requires many attempts to select an item on the screen, or if selecting items on a specific area of the screen is difficult.

The touch screen may also require calibration if the cardiograph is used in different settings (seated instead of standing) or by users of significantly different height. The touch screen may need to be recalibrated to work optimally in the new setting or with the new user.

#### To calibrate the touch screen:

- 1 Touch the **Ctrl + Alt + C** keys (on keyboard) at the same time.
- 2 A white screen appears with a cross hair (center of screen). Touch the middle of the cross hair where the two lines intersect. When the cross hair is touched it moves to a new location. Continue to touch the center of the cross hair.
- 3 Tap the screen (when a message appears) to end the test.
- 4 Touch the **Done** button to exit.

### Touch Screen Cleaning

The touch screen may require occasional cleaning.

#### To clean the touch screen:

- 1 Dampen a soft cloth with water or with isopropyl alcohol.
- 2 Wring excess moisture from the cloth.
- 3 Wipe the touch screen area clean. Allow the touch screen to dry completely before use.
- 4 Perform the Barcode Test to verify performance.

## Changing the Date and Time

The date and time that displays on the cardiograph may be changed manually, or may be configured to automatically synchronize with a specified TraceMaster server using the Time Synchronization feature. For more information on configuring the Time Synchronization feature on the cardiograph, see the *PageWriter TC70 Network Configuration Guide* on the User Documentation CD.

Follow the procedure below to manually set the date or time.

**NOTE** Opening the Setup screens may require entering a password. If a password is lost and cannot be retrieved, call the Philips Response Center for further assistance. See "Contacting a Philips Response Center" on page 1-38.



### To set the date and time:

- 1 Touch the Setup button on the main toolbar.
- 2 The Configuration Setup and Service Utilities menu appears. Touch the button next to **Configure TraceMaster and OrderVue Settings**.
- 3 The Configure Network Settings screens appear. Touch the **TraceMaster/OrderVue** button (top of screen).
- 4 The TraceMaster settings screens appear. The **Create TraceMaster Connection** tab is selected. Touch the **Edit/Delete TraceMaster Connection** tab (top of screen).
- 5 Under **Time Synchronization Settings** (middle of screen), touch the **Set** button next to **Manual Time Set**.
- 6 The Date and Time Settings window appears with the current specified date and time displayed. To change the current date, touch the back or forward arrows next to the name of the displayed month (to change the month), or touch a date on the calendar to change the date within the displayed month.
- 7 To change the displayed time, touch the hour and minutes displayed under **Current Time**, or touch the up or down arrow buttons next to the displayed time to manually change the time. Touch the time designator to change it to **AM** or to **PM**.
- 8 Touch the dropdown arrow button under **Time Zone** to change the selected time zone.

**NOTES** The time displayed on the cardiograph automatically adjusts for Daylight Savings Time, if applicable.

Touch the **Time Sync** button to manually synchronize the cardiograph date and time with a specified TraceMaster server.

- 9 Touch the **OK** button when done. Touch the **Exit** button (lower right corner of screen) to exit the Setup screen. The new time and date is immediately applied.

# Cardiograph Overall Sensitivity Test

The overall sensitivity test is used to test the calibration voltage. According to *IEC 60601-2-51*, this test should be run regularly. Taking an ECG using a 12-lead simulator allows you to verify areas of operation that the extended self tests cannot check, and allows you to verify the accuracy of the sensitivity settings. This test should be run approximately once a year.

## Before You Begin

To perform this test, you need an ECG simulator that is calibrated and is able to produce a 1mV 2 Hz square wave on Lead I or II. (The lead you use is dependent on the simulator.)

## Performing the Sensitivity Test

To perform the test:

- 1 Set the simulator to the 2Hz square wave setting and the amplitude to 1mV.
- 2 Ensure that the Simulated Mode feature is not enabled on the cardiograph.
- 3 Touch the **Exam** button on the Status Bar, and then touch the **Resting 12-Lead** button.
- 4 Touch the factory default **Standard 12-lead** Exam Profile button.
- 5 Touch the **Settings** button on the Status Bar.
  - a Set Artifact to OFF.
  - b Set Limb Leads to 10 mm/mV.
  - c Set Speed to 25 mm/sec.
  - d Touch **OK**.
- 6 Touch the **ECG** button on the toolbar. If a message appears that no patient information has been entered, touch the **Continue** button. Depending on how the cardiograph is configured, the ECG may automatically print. If not, touch the **Print** button.
- 7 Verify Lead I or II for the following items on the printed report:
  - The height of the ECG pulses for the sensitivity setting
  - Measure the peak of the ECG pulse and calculate the voltage for the sensitivity setting
  - Verify that the measured voltage value is 1mV. Count the boxes that are contained in the square wave from the top to the bottom, using the top left corner of the square wave labeled **A** in Figure 2-5 as the upper boundary, and the lower right corner of the square wave labeled **B** in Figure 2-5 as the lower boundary. The square wave should measure 10 mm (10 boxes) with a  $\pm 5\%$  margin for error.

**Figure 2-5 Overall Sensitivity Test Results**

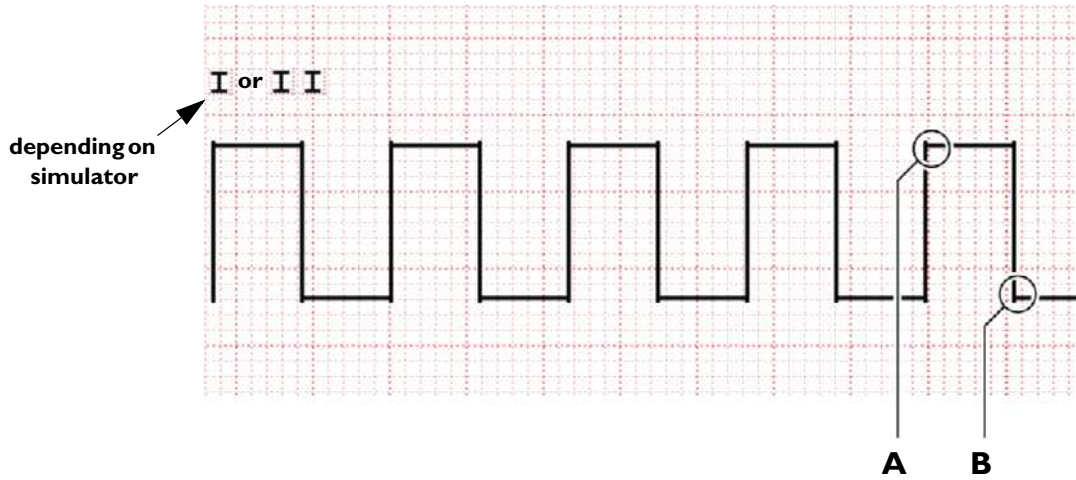

- 8 If the results fall outside of the  $\pm 5\%$  range, run the test again. If you get the same results, try running the test on a different cardiograph. If the test fails on the other cardiograph, the simulator may be out of calibration. If the test passes on the other cardiograph, it may indicate a problem with your cardiograph. Contact the Philips Response Center for further assistance.

## Cardiograph and Accessory Disposal

When the cardiograph has reached the end of its product life, dispose of it according to local ordinances. When any of the cardiograph accessories reach the end of their product life, dispose of these items in accordance with manufacturer instructions and local ordinances.





## Troubleshooting

This chapter provides information for localizing cardiograph problems to the subassembly level. This information is designed for use with the cardiograph's diagnostic self-tests to help you efficiently repair the cardiograph with a minimum of equipment.

The Philips Response Center can assist with product troubleshooting and provide technical expertise to help with any issue with the PageWriter TC 70 cardiograph or any of its accessories. For a full listing of contact phone numbers, see "Contacting a Philips Response Center" on page 5-11.

This chapter provides the following information:

Troubleshooting Cardiograph Issues . . . . .	3-2
Start up Issues . . . . .	3-3
Display Issues . . . . .	3-4
Keyboard Issues . . . . .	3-5
Signal Acquisition Issues . . . . .	3-7
Main Screen Issues . . . . .	3-10
Archive Screen Issues . . . . .	3-11
Configuration Screen Issues . . . . .	3-16
Printer Issues . . . . .	3-19
Compact Flash (CF) Card/USB Memory Stick Issues . . . . .	3-22
TraceMasterVue Issues . . . . .	3-25
Orders Issues . . . . .	3-27
Remote Query Issues . . . . .	3-29
Fax Issues . . . . .	3-31
Log File and Custom Settings Issues . . . . .	3-32
Wireless Troubleshooting . . . . .	3-33
Restarting the Cardiograph . . . . .	3-34
Running the Lead Wires Open Test . . . . .	3-35
Running the Lead Wires Short Test . . . . .	3-35
Running the Service Utilities . . . . .	3-36
Using the About the Cardiograph Screen . . . . .	3-37
Running the Diagnostic Tests and Utilities . . . . .	3-38
Running the Diagnostic Tests . . . . .	3-43
Viewing and Saving Log Files . . . . .	3-46
Saving Log Files . . . . .	3-47

## Troubleshooting Cardiograph Issues

The troubleshooting information in this section will help you to localize a fault and to correct it.

The following charts list symptoms and the steps to follow to investigate and solve the problem. Several failure mode symptoms may actually be hardware induced or triggered, and may require board replacement or opening of the cardiograph for inspection, please contact the Philips Response Center for further assistance. See “Contacting a Philips Response Center” on page 5-11.

## Start up Issues

**Table 3-1 Start up Issues**

Symptom	Possible Cause & Investigation Step	Possible Solutions
<b>Failed to implement custom settings. The cardiograph will automatically restart and restore current settings. Please contact the Philips Response Center for further assistance.</b> message	Failure to load a configuration file	<ol style="list-style-type: none"><li><b>1</b> Restore the factory default settings.</li><li><b>2</b> Contact the Philips Response Center.</li></ol>

## Display Issues

**Table 3-1 Display Issues**

Symptom	Possible Cause & Investigation Step	Solution
Screen is dark and shows no image	Cardiograph is in standby. Cardiograph battery is extremely low.	<ol style="list-style-type: none"> <li><b>1</b> Press the On/Standby button. Confirm the cardiograph wakes up.</li> <li><b>2</b> Connect cardiograph to AC power and press the On/Standby button.</li> <li><b>3</b> User training on proper use of Standby.</li> </ol>
	Power issue: AC Power AC is applied but AC Power On indicator LED is dark.	<ol style="list-style-type: none"> <li><b>1</b> Inspect AC power connections.</li> <li><b>2</b> Ensure AC cord is not damaged and is plugged into appropriate live AC power socket.</li> <li><b>3</b> Ensure AC Adaptor's power cable is connected to the power input connector on the back of the cardiograph.</li> </ol>
	Power issue: Battery AC is not attached and the battery is inserted into the cardiograph. Push the On/Standby button. The screen remains dark.	<ol style="list-style-type: none"> <li><b>1</b> Open battery compartment door and inspect battery condition.</li> <li><b>2</b> Ensure that the battery strap is fully extended before installing the battery.</li> <li><b>3</b> Replace battery.</li> </ol>
	Display assembly failure	Cardiograph must be serviced to replace display assembly. Contact the Philips Response Center.
	Main board failure	Cardiograph must be serviced to replace main board. Contact the Philips Response Center.

**Table 3-1 Display Issues** *(continued)*

Symptom	Possible Cause & Investigation Step	Solution
A dialog box shows software version information with a black background	File system is destroyed.	<ol style="list-style-type: none"> <li><b>1</b> Wait 2 minutes and perform full software installation.</li> <li><b>2</b> Confirm successful software installation.</li> </ol>

## Keyboard Issues

**Table 3-2 Keyboard Issues**

Symptom	Possible Cause & Investigation Step	Solution
Keyboard is unresponsive	Input focus lost Keyboard controller subsystem has failed.	<ol style="list-style-type: none"> <li><b>1</b> Touch the cardiograph screen anywhere.</li> <li><b>2</b> Restart cardiograph. See “Restarting the Cardiograph” on page 3-34.</li> <li><b>3</b> Perform the Service Utility Keyboard/Hardware Key test on page 3-45.</li> <li><b>4</b> If the test passes, try using the keyboard again. If the test fails, contact the Philips Response Center.  The cardiograph must be serviced to inspect and possibly replace the keyboard, cabling, or main board.</li> </ol>
ID or ECG button on keyboard is unresponsive	Input focus loss	Touch the cardiograph screen anywhere.

**Table 3-2 Keyboard Issues** *(continued)*

<b>Symptom</b>	<b>Possible Cause &amp; Investigation Step</b>	<b>Solution</b>
Keyboard is typing incorrect characters	Keyboard has Caps Lock enabled.	<ol style="list-style-type: none"> <li><b>1</b> Check to see if the Cap Lock icon appears on the cardiograph screen's status bar.</li> <li><b>2</b> Turn off the Caps Lock feature.</li> <li><b>3</b> User training on Caps Lock use.</li> </ol>

## Signal Acquisition Issues

Before attempting to troubleshoot a signal acquisition error as a mechanical issue, ensure that the following patient preparation and basic troubleshooting techniques have first been followed.

Always follow good skin and patient preparation techniques prior to taking an ECG. Proper skin preparation helps to ensure a good quality ECG. Skin is a poor conductor of electricity and frequently creates artifact that distorts the ECG signal.

### To prepare the patient for an ECG:

- 1 Shave hair from electrode sites if necessary (excessive hair prevents a good connection).
- 2 Wash the skin thoroughly with soap and water.
- 3 Dry the skin vigorously to increase capillary blood flow to the tissues and to remove the dead, dry skin cells and oil.

### NOTE

**Do not use alcohol** to clean the skin because it dries the skin. If there is no time, rub the electrode sites with gauze to remove the dead, dry skin and to increase capillary flow.

- 4 Always use disposable electrodes, and ensure that the disposable electrodes have not expired. Place the electrodes on flat, fleshy parts of the arms and legs, and place all limb electrodes equal distance from the heart, at the same position on each limb. If a limb site is not available (amputation, injury) place the electrodes closer to the torso.
- 5 For female patients, always place the electrodes on top of the breast (not underneath the breast tissue).
- 6 Ensure that all electrodes are firmly attached, and that the lead wires are not pulling on the electrodes. If the electrodes can be moved easily, the electrode connection is too loose.
- 7 Reassure the patient and make sure that the patient is comfortable. If the patient has tremors, attach the limb electrodes higher on the patient (closer to the torso), and assist with limiting patient moving while taking the ECG.

After ensuring that proper patient preparation techniques are being followed, and that fresh electrodes are being applied to the patient, review the following table for further assistance.

**Table 3-3 Signal Acquisition Issues**

Symptom	Possible Cause & Investigation Step	Solution
<p>All leads show leads off (red dashed line) <i>continuously</i></p>	<p>PIM communications have been lost due to USB patient data cable connection failure, or defective leads are connected to the PIM.</p>	<ol style="list-style-type: none"> <li><b>1</b> Check to see if the PIM icon (with the red X) appears at the top right of the screen.</li> <li><b>2</b> If the PIM is firmly attached, perform the PIM test as described in “Patient Interface Module (PIM) Test” on page 3-43. If the PIM Test fails, replace the patient data cable. If the PIM Test continues to fail with a new patient data cable attached, replace the PIM.</li> <li><b>3</b> If the PIM test passes, ensure that all lead wires are fully seated in the PIM lead connectors.</li> <li><b>4</b> Ensure that all lead wires are intact and that there are no cracks visible in any of the lead wires.</li> <li><b>5</b> Run the lead wire open and short tests, as described on page 3-35.</li> <li><b>6</b> If the lead wire open and short tests fail, contact the Philips Response Center.</li> </ol>
<p>One or more leads show leads off (red dashed line) <i>periodically</i></p>	<p>Improper or incomplete patient and skin preparation techniques</p>	<p>Ensure that good patient preparation and skin preparation techniques have been followed as described on page 3-7.</p>
	<p>Improperly attached electrodes or lead wires; expired disposable gel electrodes</p>	<ol style="list-style-type: none"> <li><b>1</b> Ensure that the lead adapters are clean and have a tight fit.</li> <li><b>2</b> Ensure that the electrodes are within their shelf life and are firmly attached to the patient.</li> </ol>
	<p>Defib or high noise event</p>	<p>Observe frequency and recovery behavior. The PIM performs an automatic ranging action when input signals vary significantly. If this behavior persists in the absence of electrode movement or defib events, the cardiograph should be serviced to inspect and possibly replace the PIM or lead cables. Contact the Philips Response Center.</p>



**Table 3-3 Signal Acquisition Issues** (continued)

Symptom	Possible Cause & Investigation Step	Solution
	PIM reset (up to ten second duration)	It is normal for the PIM to reset under the following conditions: <ul style="list-style-type: none"> <li>■ power on/wakeup</li> <li>■ screen changes</li> <li>■ insertion/removal of a USB device (USB memory stick)</li> </ul> When the PIM resets, it is normal for all leads to display red dashed lines for up to ten seconds. The PIM icon with the red X is displayed during the PIM reset.
One or more leads show leads off (red dashed line) <i>periodically</i>	PIM communications have been lost due to USB patient data cable connection failure, or defective leads are connected to the PIM.	<ol style="list-style-type: none"> <li>1 Check to see if the PIM icon (with the red X) appears at the top right of the screen.</li> <li>2 If the PIM is firmly attached, perform the PIM test as described in “Patient Interface Module (PIM) Test” on page 3-43. If the PIM Test fails, replace the patient data cable. If the PIM Test continues to fail with a new patient data cable attached, replace the PIM.</li> <li>3 If the PIM test passes, ensure that all lead wires are fully seated in the PIM lead connectors.</li> <li>4 Ensure that all lead wires are intact and that there are no visible cracks in the lead wires.</li> <li>5 Run the lead wire open and short tests, as described on page 3-35.</li> <li>6 If the lead wire open and short tests fail, contact the Philips Response Center.</li> </ol>
<b>Patient Interface Module (PIM) not detected</b> message or PIM with red X icon appears on screen	PIM not connected Faulty patient data cable Faulty PIM	<ol style="list-style-type: none"> <li>1 Check that PIM patient data cable is firmly seated to the PIM connector (E) on the rear of the cardiograph.</li> <li>2 If the PIM is firmly attached, perform the PIM test as described in “Patient Interface Module (PIM) Test” on page 3-43. If the PIM Test fails, replace the patient data cable. If the PIM Test continues to fail with a new patient data cable attached, replace the PIM. Contact the Philips Response Center.</li> </ol>

## Main Screen Issues

**Table 3-4 Real Time Screen Issues**

Symptom	Possible Cause & Investigation Step	Solution
Waveform display is no longer updating, system is unresponsive	Main board failure	Restart the cardiograph. See “Restarting the Cardiograph” on page 3-34.  The cardiograph must be serviced to replace the main board. Contact the Philips Response Center.
<b>Invalid Report Handle</b> message	Report handle is invalid when preview, printing, saving ECGs.	<ol style="list-style-type: none"> <li><b>1</b> Restart the cardiograph. See “Restarting the Cardiograph” on page 3-34.</li> <li><b>2</b> Wait 2 minutes and perform full software installation. Confirm successful software installation.</li> </ol>
<b>No Report</b> message	The software can't map the input report handle to the internal report object. The handle is invalid.	<ol style="list-style-type: none"> <li><b>1</b> Restart the cardiograph. See “Restarting the Cardiograph” on page 3-34.</li> <li><b>2</b> Wait 2 minutes and perform full software installation. Confirm successful software installation.</li> </ol>
<b>Internal function error</b> message	Invalid file or the file resides on unsupported media.	<ol style="list-style-type: none"> <li><b>1</b> Restart the cardiograph. See “Restarting the Cardiograph” on page 3-34.</li> <li><b>2</b> Wait 2 minutes and perform full software installation. Confirm successful software installation.</li> </ol>

## Archive Screen Issues

**Table 3-5** Archive Screen Issues

<b>Symptom</b>	<b>Possible Cause &amp; Investigation Step</b>	<b>Solution</b>
<b>Command timed-out</b> message	The TraceMaster ECG Management system is busy.	Retry TraceMaster operation. Transfer operations use network and server resource, which may occasionally be unable to service the requests.
<b>ECGs with incomplete required patient information fields cannot be transferred</b> message	The required information for the ECG has not been entered.	Enter the required ECG information and try the archive operation again.
<b>Selected ECG(s) exceeds available space on TraceMaster Remote site</b> message	The TraceMaster system is out of available disk space.	Contact the TraceMaster system administrator and report the error.

**Table 3-5** Archive Screen Issues (continued)

Symptom	Possible Cause & Investigation Step	Solution
<b>Requested Function could not be completed</b> message	Network or modem phone line was interrupted during operation.	<ol style="list-style-type: none"> <li>1 Retry operation.</li> <li>2 Inspect cabling to network or analog phone line. Transfer or query operations require reliable access to the network transport.</li> </ol>
	USB memory stick was not fully inserted into the slot on the cardiograph.	<ol style="list-style-type: none"> <li>1 Verify that the USB memory stick is inserted correctly. Attempting to save ECGs to USB memory stick that is not accessible will result in an error message.</li> <li>2 Retry the operation with fully functioning USB memory stick that is fully inserted into the USB slot on the cardiograph.</li> </ol>
	An attempt to transfer an unsupported ECG report type (format is Pan-12 or 12x1) was made to TraceMaster.	<p>Inspect ECG that failed the requested operation for selected format (report type).</p> <p>Certain ECG report types are not supported by and will be rejected by the TraceMaster ECG Management System.</p>
<b>Insufficient storage available</b> message appears when you are attempting to transfer files to the USB memory stick.	There is not enough space on the USB memory stick.	<ol style="list-style-type: none"> <li>1 Check the USB memory stick storage capacity.</li> <li>2 Free up space on the USB memory stick by deleting files and retry the operation.</li> </ol>
<b>Invalid database</b> message	Archive database may be corrupted.	<ol style="list-style-type: none"> <li>1 Restart the cardiograph. See “Restarting the Cardiograph” on page 3-34.</li> <li>2 Wait 2 minutes and perform full software installation. Confirm successful software installation.</li> </ol>
When an error occurs during transfer of multiple ECGs to a TraceMaster system, the transfer process does not continue and transferred files are not deleted.	Application limitation	<p>The PageWriter TC 70 operations fail in a known safe manner when multiple ECG transfer operations are interrupted.</p> <p>Retry the transfer for the remaining ECGs.</p>

**Table 3-5 Archive Screen Issues** (continued)

Symptom	Possible Cause & Investigation Step	Solution
<p>After pressing the <b>Archive</b> button, it takes longer than 40 seconds before the Archive list is displayed when the main archive has more than 130 ECGs stored.</p>	<p>System slow-down from full ECG database</p>	<p>Save or delete ECGs from the Main Archive. There is a known system performance impact when the near maximum number of ECGs have been stored in the main archive area.</p>
<p>Transfer of ECGs to a USB memory stick fails and there are still less than 200 ECGs on the removable media device.</p>	<p>USB memory stick file system limitation</p>	<p>Delete unwanted files from the USB memory stick.</p>
<p><b>No reply received from TraceMaster Remote site</b> message</p>	<ul style="list-style-type: none"> <li>■ The server is unavailable.</li> <li>■ Configuration error</li> </ul>	<ol style="list-style-type: none"> <li><b>1</b> Contact the TraceMasterVue system administrator and report the error.</li> <li><b>2</b> Check the IP address and the TraceMaster server URL in the TraceMaster configuration settings.</li> </ol>
<p><b>Archive function could not be completed. Please restart cardiograph and try again.</b> message</p>	<p>Archive error</p>	<p>Restart the cardiograph. See “Restarting the Cardiograph” on page 3-34.</p>
<p><b>Archive process was terminated due to an error</b> message</p>	<p>Archive error</p>	<p>Restart the cardiograph. See “Restarting the Cardiograph” on page 3-34.</p>
<p><b>Bad reply received from TraceMaster Remote site</b> message</p>	<p>Archive error, bad reply from server</p>	<ol style="list-style-type: none"> <li><b>1</b> Restart the cardiograph. See “Restarting the Cardiograph” on page 3-34.</li> <li><b>2</b> Contact the TraceMasterVue system administrator and report the error.</li> </ol>
<p><b>Unexpected reply received from TraceMaster Remote Site</b> message</p>	<p>Archive error, unexpected reply from server</p>	<ol style="list-style-type: none"> <li><b>1</b> Restart the cardiograph. See “Restarting the Cardiograph” on page 3-34.</li> <li><b>2</b> Contact the TraceMasterVue system administrator and report the error.</li> </ol>

**Table 3-5 Archive Screen Issues** *(continued)*

Symptom	Possible Cause & Investigation Step	Solution
<b>Invalid XML schema version</b> message	Archive error, unsupported XML schema	<ol style="list-style-type: none"> <li><b>1</b> Restart the cardiograph. See “Restarting the Cardiograph” on page 3-34.</li> <li><b>2</b> Contact the Philips Response Center.</li> </ol>
<b>Unsupported XML version</b> message	XML schema of selected ECG is not supported by TraceMasterVue server.	<ol style="list-style-type: none"> <li><b>1</b> Check the TraceMaster configuration settings screens to ensure that the correct TraceMaster server version is selected.</li> <li><b>2</b> Contact the Philips Response Center.</li> </ol>
<b>XML error</b> message	XML ECG file corrupted	Contact the Philips Response Center.
<b>XML unicode encoding is not UTF-16</b> message	Invalid encoding	Contact the Philips Response Center.
<b>Error accessing external XML file</b> message	File I/O error	Contact the Philips Response Center.
<b>Error XML file is too large</b> message	File is too large	Contact the Philips Response Center.
<b>Error XML file did not transform</b> message	File I/O error	Contact the Philips Response Center.
<b>Fax transmission did not complete</b> message	Fax not completed	Retry the fax operation
<b>There is no default TraceMaster server available for Auto Time Sync</b> message	TraceMasterVue settings are not configured correctly.	Check the TraceMasterVue configuration settings on the cardiograph.

**Table 3-5 Archive Screen Issues** (continued)

Symptom	Possible Cause & Investigation Step	Solution
<p>Some ECGs retrieved from TraceMaster and printed on the cardiograph look different from TraceMaster prints or XLi printouts.</p>	<p>Older or non-PageWriter TC 70 source ECG files were retrieved. ECG was not created by a PageWriter TC 70 cardiograph.</p>	<p>Inspect the printed report date and information</p> <p>Retrieving and printing older ECG files that were not sourced by the PageWriter TC 70 cardiograph can have the following differences when printed:</p> <ul style="list-style-type: none"> <li>■ Algorithm version appears as HPxxx on TraceMaster and PH on PageWriter TC 70.</li> <li>■ Pacer tick marks are not present on PageWriter TC 70 printout.</li> <li>■ Frank lead system generates 3 rhythm traces with flat line and no lead label on PageWriter TC 70 printout.</li> <li>■ Custom lead names do not appear on PageWriter TC 70 printout.</li> <li>■ PageWriter TC 70 prints full interpretations regardless of original Xli ECG settings.</li> </ul>
<p><b>Error occurred when deleting the selected ECGs. Please check the Error List below message</b></p>	<p>Internal Compact Flash card read/write error</p>	<ol style="list-style-type: none"> <li>1 Retry the operation.</li> <li>2 Contact the Philips Response Center.</li> </ol>
<p><b>Error occurred when transferring the selected ECGs. Please check the Error List below for more details. message</b></p>	<p>Transmission error</p>	<ol style="list-style-type: none"> <li>1 Retry the operation.</li> <li>2 Contact the Philips Response Center.</li> </ol>
<p><b>Do you want to overwrite the existing patient information with the selected order message</b></p>	<p>You attempted to use an order to overwrite patient information of an archived ECG.</p>	<p>Check to make sure that you want to overwrite the information. If so, confirm the operation. If not, cancel the operation.</p>

## Configuration Screen Issues

**Table 3-6 Configuration Screen Issues**

Symptom	Possible Cause & Investigation Step	Solution
<b>The maximum number of TraceMaster connections has been configured. Please edit or delete an existing TraceMaster connection.</b> message	There are a limited number of TraceMaster connections that can be configured on the cardiograph.	Remove one of the TraceMaster connections.
<b>The maximum number of OrderVue inboxes has been created. Edit or delete an existing inbox.</b> message	There are a limited number of OrderVue inboxes that can be configured on the cardiograph.	Remove one of the OrderVue inboxes.
<b>Invalid XML version detected. Please try again.</b> message	Invalid version detected when loading configuration file.	Reconfigure the cardiograph manually.
<b>Invalid XML platform detected. Please try again.</b> message	Invalid platform detected when loading configuration file.	Reconfigure the cardiograph manually.
<b>Invalid XML file detected. Please try again.</b> message	Invalid configuration file detected when loading configuration file.	<ol style="list-style-type: none"> <li>1 Ensure you are selecting a configuration file.</li> <li>2 Reconfigure the cardiograph manually.</li> </ol>
<b>Failed to implement custom settings. The cardiograph will automatically restart and restore custom settings.</b> message	Corrupted configuration file detected when loading configuration file.	<ol style="list-style-type: none"> <li>1 Cardiograph automatically restarts and loads current configuration.</li> <li>2 Reconfigure the cardiograph manually.</li> </ol>
<b>Duplicate Profile name. Please enter a unique name.</b> message	You attempted to save an exam profile under an existing name.	Choose another name and save the exam profile.



**Table 3-6 Configuration Screen Issues** *(continued)*

<b>Symptom</b>	<b>Possible Cause &amp; Investigation Step</b>	<b>Solution</b>
<b>Password is missing. Please re-enter your password before continuing.</b> message	The Configuration screen is password protected and you did not enter a password.	Enter the correct password to gain access to the configuration screens.
<b>Password is not confirmed. Confirm your password before proceeding.</b> message	You enabled the Configuration password but did not confirm it.	Confirm the configuration password after entering it.
<b>The maximum number of fax profiles has been configured. Please edit or delete an existing fax profile.</b> message	There is a current system limitation of one fax profile.	Edit or delete an existing fax profile.
<b>Please select a TraceMaster server as the default connection</b> message	You attempted to set a default TraceMasterVue server without first selecting it.	You must first select a TraceMaster server before it can be set as the default.
<b>The cardiograph must restart in order to display simulated waveform data</b> message	The cardiograph's simulation mode was turned on and the device must be restarted to display simulated waveform data.	Touch <b>OK</b> to restart the cardiograph.
<b>The cardiograph must restart in order to return to normal operating mode</b> message	The cardiograph's simulation mode was turned off and the device must be restarted to return to normal operation mode.	Touch <b>OK</b> to restart the cardiograph.
<b>Unsaved changes will be deleted. Do you want to continue and discard changes?</b> message	After making a configuration change, you touched the Exit button without saving the change.	Save any configuration changes before exiting the configuration screens.

**Table 3-6 Configuration Screen Issues** *(continued)*

Symptom	Possible Cause & Investigation Step	Solution
<b>Invalid name. Please save again with a different name.</b> message	You attempted to create a TraceMaster server or a fax recipient without entering a name.	Check the TraceMaster and Fax configuration settings and enter a valid name.
<b>This TraceMasterVue server name is already in use. Please enter a different name.</b> message	You attempted to configure a TraceMasterVue server name that is already in use.	Check the TraceMaster configuration settings and specify another server name.
<b>Please enable Admin Password before enabling this password</b> message	You attempted to enable an Archive, Configuration, or Service password without first enabling as Admin password.	<ol style="list-style-type: none"> <li><b>1</b> Configure an Admin password first.</li> <li><b>2</b> Configure the other passwords.</li> </ol>
<b>Please disable all user passwords before disabling this one</b> message	You attempted to disable the Admin password without first disabling the Archive, Configuration, or Service password.	<ol style="list-style-type: none"> <li><b>1</b> Disable the Admin password first.</li> <li><b>2</b> Disable the other passwords.</li> </ol>
<b>The number of minutes set for 'Shut Down' must be greater than the number of minutes set for 'Standby'</b> message	You attempted to configure the shut down time to be less than the Standby time.	Configure the Shut down time to be greater than the Standby time

## Printer Issues

**Table 3-7 Printer Issues**

Symptom	Possible Cause & Investigation Step	Solution
The message <b>Busy</b> appears after you have sent a job to the printer.	A new print job has been sent to the printer and the printer cannot accept a new print job.	Restart the cardiograph. See “Restarting the Cardiograph” on page 3-34.
The message <b>USB</b> appears when attempting to print a rhythm strip.	A new print job has been sent to the printer and the printer cannot accept a new print job.	Restart the cardiograph. See “Restarting the Cardiograph” on page 3-34.
<b>Printing is disabled with one battery only, please check the battery</b> message	Cannot print with one battery	Insert the second battery.
<b>Low battery warning: printing is disabled. Connect the cardiograph to AC power and recharge the batteries</b> message appears after you have sent a job to the printer.	No battery or dead battery	Plug the cardiograph into AC power or replace the battery.
<b>Field Programmable Gate Array (FPGA) communication is incorrectly configured. Please contact the Philips Response Center for further assistance.</b> message	Internal error	Contact the Philips Response Center.
<b>Field Programmable Gate Array (FPGA) is not connected. Please contact the Philips Response Center for further assistance.</b> message.	Internal error	Contact the Philips Response Center.

**Table 3-7 Printer Issues** (continued)

Symptom	Possible Cause & Investigation Step	Solution
<b>Printer temperature is too high</b> message	The temperature of the print head is too high.	<ol style="list-style-type: none"> <li>1 Shut down cardiograph and wait 20 minutes.</li> <li>2 If error persists, contact the Philips Response Center.</li> </ol>
<b>Printer underflow.</b> message	Intermittent PIM communication issues during rhythm printing	Follow the steps in Table 3-3, “Signal Acquisition Issues,” on page 3-8 for PIM signal acquisition issues.
<b>Printer voltage high</b> message.	Printer supply voltage on main board is outside of expected ranges on the high side.	If message persists, contact the Philips Response Center.
<b>Printer voltage low.</b> message	Printer supply voltage on main board is outside of expected ranges on the low side.	If message persists, contact the Philips Response Center.
<b>Printer Door is Open</b> message	Printer door is open.	<ol style="list-style-type: none"> <li>1 Close the printer door.</li> <li>2 Restart the cardiograph. See “Restarting the Cardiograph” on page 3-34.</li> </ol>
<b>Check Printer</b> message appears with no apparent printer problem present.	Printer controller error Printer cable inside cardiograph has become dislodged.	<ol style="list-style-type: none"> <li>1 Open and close printer paper drawer. Message does not reoccur.</li> <li>2 If message persists, contact the Philips Response Center.</li> <li>3 The cardiograph must be serviced to check inside cables. Contact the Philips Response Center.</li> </ol>
Printed report looks too small or compressed.	Printer controller error	<ol style="list-style-type: none"> <li>1 Run the Printer Test from the Service Utilities on page 3-39.</li> <li>2 If test passes, retry print operation.</li> <li>3 If test fails, restart the cardiograph. See “Restarting the Cardiograph” on page 3-34.</li> <li>4 If the problem persists, contact the Philips Response Center.</li> </ol>

**Table 3-7 Printer Issues** (continued)

Symptom	Possible Cause & Investigation Step	Solution
After opening and closing the paper drawer rapidly many times, the cardiograph was unresponsive.	Printer controller error	<ol style="list-style-type: none"> <li>Restart the cardiograph. See “Restarting the Cardiograph” on page 3-34. Cardiograph restarts and boots correctly. Reports print correctly.</li> <li>If the problem persists, contact the Philips Response Center.</li> </ol>
<b>Printer Error: Out of Paper/Paper Jam/Door Open</b> messages	<ul style="list-style-type: none"> <li>■ Paper drawer is not fully closed</li> <li>■ Out of paper, or paper loaded incorrectly with top-of-form hole on wrong side</li> <li>■ Incompatible paper loaded</li> <li>■ Defective paper tray assembly</li> <li>■ Top-of-form sensor or door closed sensor issue</li> </ul>	<ol style="list-style-type: none"> <li>Make sure paper drawer is fully closed.</li> <li>Reload the paper. Confirm that paper is loaded correctly.</li> <li>Confirm that the paper is compatible with the Philips approved paper (see Ordering Supplies in Chapter 4).</li> <li>Replace the paper tray assembly.</li> <li>The cardiograph must be serviced to check the sensors. Contact the Philips Response Center.</li> </ol>
<b>Printer not detected</b> message	<ul style="list-style-type: none"> <li>■ Application error</li> <li>■ Defective print head assembly</li> </ul>	<ol style="list-style-type: none"> <li>Restart the cardiograph. See “Restarting the Cardiograph” on page 3-34.</li> <li>The cardiograph must be serviced to replace the print head assembly. Contact the Philips Response Center.</li> </ol>
Paper does not advance	<ul style="list-style-type: none"> <li>■ Application error</li> <li>■ Top-of-form sensor issue</li> <li>■ Defective print head assembly</li> </ul>	<ol style="list-style-type: none"> <li>Restart the cardiograph. See “Restarting the Cardiograph” on page 3-34.</li> <li>The cardiograph must be serviced to check the sensor or replace the print head assembly. Contact the Philips Response Center.</li> </ol>
Paper does not tear off cleanly, or paper stops at the wrong spot	<ul style="list-style-type: none"> <li>■ Wrong paper size setting</li> <li>■ Wrong method is being used to tear off paper</li> </ul>	Reload printer with correct paper size. See the “Printer Paper” section in the <i>PageWriter TC 70 Instructions for Use</i> for correct method.
Blank pages printed after ECG report	Wrong paper size setting	Reload printer with correct paper size.

**Table 3-7 Printer Issues** (continued)

Symptom	Possible Cause & Investigation Step	Solution
Print Error: Unknown Error	Application timing issue	<ol style="list-style-type: none"> <li><b>1</b> End the patient session and restart a new patient session.</li> <li><b>2</b> Restart the cardiograph. See “Restarting the Cardiograph” on page 3-34.</li> </ol>

## Compact Flash (CF) Card/USB Memory Stick Issues

**Table 3-8 Compact Flash Card / USB Memory Stick Issues**

Symptom	Possible Cause & Investigation Step	Solution
Occasionally, copying ECGs from archive to a USB Memory Stick fails.	USB memory stick subsystem time-out failure	<ol style="list-style-type: none"> <li><b>1</b> Retry the transfer operation. Write operations occasionally fail for USB memory sticks.</li> <li><b>2</b> If this condition reoccurs persistently, replace the USB Memory Stick. Not all USB memory sticks are supported. See “Ordering Options and Upgrades” on page 5-10 for information on ordering a Philips supported USB memory stick.</li> </ol>
<b>Maximum number of ECGs stored</b> message	CF card file system limitation	Delete files from the Archive.
<b>Cannot store additional ECGs</b> message	CF card file system limitation	Delete unwanted files from the CF card
<b>Cannot access internal Compact Flash memory</b> message	Compact Flash may be corrupted.	<ol style="list-style-type: none"> <li><b>1</b> Run the Internal Compact Flash test from the Service Utilities on page 3-45.</li> <li><b>2</b> If the test passes, retry the operation.</li> <li><b>3</b> If the test fails, the Compact Flash card needs to be replaced. The cardiograph must be serviced to replace the Compact Flash card. Contact the Philips Response Center.</li> </ol>

**Table 3-8 Compact Flash Card / USB Memory Stick Issues** *(continued)*

Symptom	Possible Cause & Investigation Step	Solution
<p><b>There are more than 200 ECGs stored on the USB memory stick. Only the first 200 ECGs will display on the cardiograph. Please store no more than 200 ECGs on the USB memory stick.</b> message</p>	<p>USB memory stick file system limitation</p>	<p>Delete unwanted files from the USB memory stick.</p>
<p><b>An unknown error occurred when accessing the storage capacity of the selected archive</b> message</p>	<p>Abnormal error occurs when getting storage capacity of selected storage media.</p>	<ol style="list-style-type: none"> <li><b>1</b> Retry the operation.</li> <li><b>2</b> If this condition reoccurs persistently, replace the USB Memory Stick. Not all USB memory sticks are supported. See “Ordering Options and Upgrades” on page 5-10 for information on ordering a Philips supported USB memory stick.</li> </ol>
<p><b>The USB memory stick is not accessible. Please ensure that the USB memory stick is fully inserted into the USB connector (right side of cardiograph).</b> message</p>	<ul style="list-style-type: none"> <li>■ The USB memory stick was not fully inserted into the slot on the cardiograph.</li> <li>■ The USB memory stick contains unsupported software (such as SanDisk U3 Desktop software).</li> </ul>	<ol style="list-style-type: none"> <li><b>1</b> Verify that the USB memory stick is inserted correctly. Attempting to save ECGs to a USB memory stick that is not accessible will result in an error message.</li> <li><b>2</b> Uninstall any software that is on the USB memory stick and format the drive.</li> <li><b>3</b> Retry the operation with fully functioning USB memory stick that is fully inserted into the USB connector on the cardiograph. Not all USB memory sticks are supported. See “Ordering Options and Upgrades” on page 5-10 for information on ordering a Philips supported USB memory stick.</li> </ol>
<p><b>The internal CompactFlash (CF) card cannot be accessed. Please contact the Philips Response Center.</b> message.</p>	<p>Compact Flash may be corrupted.</p>	<p>The cardiograph must be serviced to replace the Compact Flash card. Contact the Philips Response Center.</p>

**Table 3-8 Compact Flash Card / USB Memory Stick Issues** *(continued)*

<b>Symptom</b>	<b>Possible Cause &amp; Investigation Step</b>	<b>Solution</b>
<b>An unknown error occurred when accessing the storage capacity of the selected archive message</b>	Abnormal error occurs when getting storage capacity of selected storage media.	Contact the Philips Response Center.
<b>Cannot disconnect the modem connection from TraceMaster Remote Site. message</b>	Failed to disconnect from TraceMasterVue via modem	Contact the Philips Response Center.
<b>Selected ECG(s), exceeds available Archive space on USB Memory Stick message</b>	USB memory stick file system limitation	Delete unwanted files from the USB memory stick.
<b>Timed ECG number exceeds available number in Main Archive message</b>	Storage capacity check for saving timed ECG	Delete unwanted files from the Main archive.



## TraceMasterVue Issues

**Table 3-9 TraceMaserVue Issues**

Symptom	Possible Cause & Investigation Step	Possible Solutions
<b>Error. The lead system used to generate this ECG is not supported on the cardiograph. Please print ECG directly from TraceMaster.</b> message	ECG XML version is incompatible	Print the ECG from TraceMasterVue.
<b>Error. The ECG originated from a legacy TraceMaster system and cannot be printed. Please print ECG directly from TraceMaster.</b> message	ECG XML version is incompatible	Print the ECG from TraceMasterVue.
<b>The Patient ID field must be enabled in order to transfer ECGs to TraceMasterVue. Touch the [ON] button underneath the “Enabled” column to activate the Patient ID field.</b> message	You attempted to transfer an ECG without a Patient ID to TraceMasterVue.	<ol style="list-style-type: none"> <li><b>1</b> Follow the on screen instructions to enter a Patient ID.</li> <li><b>2</b> Retry the transfer operation.</li> </ol>
<b>Required patient information is missing from the current ECG</b> message	You attempted to transfer an ECG without the required information to TraceMasterVue.	Enter the required information and attempt the operation again.

**Table 3-9 TraceMasterVue Issues** (continued)

Symptom	Possible Cause & Investigation Step	Possible Solutions
<p><b>There are no TraceMaster connections configured for use. Please go to Setup and add a TraceMaster connection.</b> message</p>	<p>You attempted to access a TraceMasterVue server and no connection has been configured.</p>	<ol style="list-style-type: none"> <li><b>1</b> Check the cardiograph's TraceMaster configuration settings and ensure a valid TraceMasterVue server is configured.</li> <li><b>2</b> Check the cardiograph's LAN/WLAN configuration settings.</li> </ol>
<p><b>There is no TraceMaster server selected as the default configuration. Please go to Setup and select a default TraceMaster connection.</b> message</p>	<p>You did not configure a default TraceMasterVue server.</p>	<ol style="list-style-type: none"> <li><b>1</b> Check the cardiograph's TraceMaster configuration settings and ensure a valid TraceMasterVue server is configured as the default TraceMaster server.</li> <li><b>2</b> Check the cardiograph's LAN/WLAN configuration settings.</li> </ol>
<p><b>Invalid transfer destination is selected</b> message</p>	<p>You selected an invalid TraceMasterVue server.</p>	<ol style="list-style-type: none"> <li><b>1</b> Check the cardiograph's TraceMaster configuration.</li> <li><b>2</b> Check the cardiograph's LAN/WLAN settings.</li> </ol>
<p><b>The XML version associated with this ECG is not supported by TraceMaster</b> message</p>	<p>ECG XML version is incompatible</p>	<ol style="list-style-type: none"> <li><b>1</b> Check the cardiograph's TraceMaster configuration settings and ensure the correct TraceMaster server version is selected.</li> <li><b>2</b> Check the cardiograph's LAN/WLAN configuration settings.</li> </ol>
<p><b>There is no TraceMaster server to delete</b> message</p>	<p>You attempted to delete a TraceMasterVue server without first selecting one.</p>	<ol style="list-style-type: none"> <li><b>1</b> Select the TraceMasterVue server to delete.</li> <li><b>2</b> Delete the TraceMasterVue server.</li> </ol>
<p><b>Missing network settings information. Please enter correct and complete network settings.</b> message</p>	<p>You attempted to configure a TraceMasterVue without specifying all of the correct information.</p>	<ol style="list-style-type: none"> <li><b>1</b> Check the cardiograph's TraceMaster configuration settings and ensure that all of the necessary information has been entered.</li> <li><b>2</b> Check the cardiograph's LAN/WLAN configuration settings.</li> </ol>

## Orders Issues

**Table 3-10 Orders Issues**

Symptom	Possible Cause & Investigation Step	Possible Solutions
<b>Command cannot be completed</b> message	The TraceMasterVue system is busy.	<p>Retry TraceMaster operation.</p> <p>Transfer operations use network and server resource, which may occasionally be unable to service the requests.</p>
<b>Command canceled</b> message	You canceled the action or specified invalid information.	Check the information specified and try again.
<b>Internal error</b> message	The orders list does not refresh.	<ol style="list-style-type: none"> <li><b>1</b> Retry the operation.</li> <li><b>2</b> Contact the Philips Response Center.</li> </ol>
<b>There is not enough internal storage available to save new orders</b> message	Application limitation	Delete unwanted orders.
<b>There is not enough internal storage available to download new orders</b> message	Application limitation	Delete unwanted orders.
<b>Not all orders can be downloaded because the Worklist is full</b> message	Application limitation	Delete unwanted orders.
<b>Orders cannot be downloaded because they have been previously archived with ECGs. Please check ECGs saved to the Main Archive.</b> message	Order to be downloaded is already used to archive an ECG.	Transmit the ECGs to TraceMasterVue.

**Table 3-10 Orders Issues** (continued)

Symptom	Possible Cause & Investigation Step	Possible Solutions
<b>Invalid default TraceMaster connection for selected OrderVue inbox. Please select the correct TraceMaster connection for the inbox.</b> message	Incorrect TraceMasterVue specified in the configuration.	<ol style="list-style-type: none"> <li>1 Check the cardiograph's TraceMaster configuration settings.</li> <li>2 Check the cardiograph's LAN/WLAN configuration settings.</li> </ol>
<b>Order Error: Requested function failed</b> message	Order application error	Contact the Philips Response Center.
<b>Order Error: XML error</b> message	XML order error	Contact the Philips Response Center.
<b>Orders number reached the limit of 200. Not all of the new orders were appended.</b> message	Application limitation	<ol style="list-style-type: none"> <li>1 Delete unwanted orders.</li> <li>2 Refine your search criteria.</li> </ol>
<b>The connection to the server was reset</b> message	The network connection was broken during an orders operation.	<ol style="list-style-type: none"> <li>1 Retry the operation.</li> <li>2 Contact your IT department to report the network is down.</li> </ol>
<b>No order source selected</b> message	You attempted to get an order without specifying a source.	Specify the source and retry the operation.
<b>Please select at least one order</b> message	You touched the ECG button without selecting an order.	<ol style="list-style-type: none"> <li>1 Select an order.</li> <li>2 Touch the ECG button.</li> </ol>
<b>Are you sure you want to delete the selected order(s)?</b> message	You attempted to delete an order.	Check to make sure that you want to delete the selected order. If so, confirm the operation. If not, cancel the operation.
<b>Selection exceeds maximum number of outboxes. Select no more than 12 outboxes.</b> message	Application limitation	Select fewer outboxes and retry the operation.

**Table 3-10 Orders Issues** (continued)

Symptom	Possible Cause & Investigation Step	Possible Solutions
<b>The Order Search Range cannot be left empty. Please enter a number between 0 and 99.</b> message	You attempted to search for an order without specifying the search range.	Specify a search range and retry the operation.

## Remote Query Issues

**Table 3-11 Remote Query Issues**

Symptom	Possible Cause & Investigation Step	Possible Solutions
<b>Remote Query could not be completed</b> message	XML application was not successfully created due to a lack of system resources.	<ol style="list-style-type: none"> <li>1 Retry the operation.</li> <li>2 Restart the cardiograph. See “Restarting the Cardiograph” on page 3-34.</li> </ol>
<b>Remote Query get list error</b> message	TraceMaster returned the wrong ECG list.	<ol style="list-style-type: none"> <li>1 Check the cardiograph’s TraceMaster configuration settings.</li> <li>2 Check the cardiograph’s LAN/WLAN configuration settings.</li> <li>3 Retry the operation.</li> </ol>
<b>Remote Query get ECG error</b> message	TraceMaster returned the wrong ECG file.	<ol style="list-style-type: none"> <li>1 Check the cardiograph’s TraceMaster configuration settings.</li> <li>2 Check the cardiograph’s LAN/WLAN configuration settings.</li> <li>3 Check to see if the TraceMaster server is up and running.</li> </ol>
<b>Remote transfer error appears</b> message	Unknown transfer error including no reply and unexpected reply.	<ol style="list-style-type: none"> <li>1 Check the cardiograph’s TraceMaster configuration settings.</li> <li>2 Check the cardiograph’s LAN/WLAN configuration settings.</li> <li>3 Retry the operation.</li> </ol>

**Table 3-11 Remote Query Issues** (continued)

Symptom	Possible Cause & Investigation Step	Possible Solutions
<b>No reply received from server</b> message	<ul style="list-style-type: none"> <li>■ The LAN connection may have been disconnected during the transfer operation.</li> <li>■ Server may be down.</li> </ul>	<ol style="list-style-type: none"> <li><b>1</b> Check the LAN connection.</li> <li><b>2</b> Check to see if the TraceMaster server is up and running.</li> </ol>
<b>Unexpected reply received from server</b> message	Server may be down.	<ol style="list-style-type: none"> <li><b>1</b> Check the LAN connection.</li> <li><b>2</b> Check to see if the TraceMaster server is up and running.</li> </ol>
<b>Remote transfer schema error</b> message	The XML schema is not supported for the selected TraceMaster server.	Check the TraceMaster Server Version in the cardiograph's TraceMaster configuration settings.
<b>No matching ECG is found on the selected server</b> message	<ul style="list-style-type: none"> <li>■ The Patient ID may be incorrect.</li> <li>■ The ECG you are looking for does not exist on the selected server.</li> </ul>	<ol style="list-style-type: none"> <li><b>1</b> Check the Patient ID.</li> <li><b>2</b> Check to see if there is an ECG with the same Patient ID.</li> </ol>

## Fax Issues

**Table 3-12 Log File Issues**

Symptom	Possible Cause & Investigation Step	Possible Solutions
<b>Fax transmission did not complete</b> message	Fax not completed	Retry the fax operation
<b>There is no fax recipient available to edit</b> message	You attempted to edit a fax recipient without first selecting one.	<ol style="list-style-type: none"> <li><b>1</b> Select a fax recipient.</li> <li><b>2</b> Edit the fax recipient.</li> </ol>
<b>Missing fax recipient information. Please enter correct fax recipient settings.</b> message	You attempted to enter a fax recipient without all of the required information.	Enter all of the required information in the Fax configuration screens.

## Log File and Custom Settings Issues

**Table 3-13 Log File Issues**

Symptom	Possible Cause & Investigation Step	Possible Solutions
<b>Error accessing file message</b>	You can't copy files from a USB memory stick when attempting to load a configuration or log file.	<ol style="list-style-type: none"> <li><b>1</b> Retry the operation</li> <li><b>2</b> Make sure the file exists on the USB memory stick.</li> </ol>
<b>Error damaged file message</b>	You can't open a file due to a corrupted file.	Retry the operation
<b>File already exists message</b>	You attempted to save a log file to an existing file.	Rename the log file and retry the operation.
<b>Input error message</b>	Invalid path and file name were specified.	Check the path and file name and ensure they are correct.
<b>No filename specified message</b>	You did not specify a file name in the Browse dialog box.	Specify a file name in the Browse dialog box.
<b>Invalid filename specified message</b>	You did not specify a file name in the Save Logs dialog box.	Specify a file name in the Save Logs dialog box.
<b>USB memory stick is not detected. Please ensure that the USB memory stick is fully inserted into the USB connector (right side of cardiograph). message</b>	Custom settings or log files cannot be saved because there is no USB memory stick in the cardiograph's USB connector.	Insert a USB memory stick into the cardiograph's USB connector (right side of cardiograph as the device is facing you).
<b>The cardiograph must restart in order to load a new custom settings file message</b>	A configuration file has been loaded.	Restart the cardiograph to use the new configuration settings.



## Wireless Troubleshooting

All wireless LAN troubleshooting topics are included in this section. For further assistance with configuring the cardiograph for wireless transmission to a TraceMasterVue ECG Management System, see the *Installing TraceMasterVue and Configuring Communication Guide* available for download from the Philips InCenter web site ([incenter.medical.philips.com](http://incenter.medical.philips.com)).

**Table 3-14 Wireless Issues**

Symptom	Possible Cause & Investigation Step	Possible Solutions
<b>LAN/WLAN connection is not available</b> message	The network connection has been broken.	Contact your IT department.
<b>Invalid IP Address</b> message	Incorrect IP address specified in the cardiograph's TraceMasterVue configuration.	<ol style="list-style-type: none"> <li>1 Check the cardiograph's TraceMaster configuration settings.</li> <li>2 Contact the TraceMasterVue system administrator for information.</li> </ol>
<b>Invalid Subnet Mask</b> message	Incorrect subnet mask specified in the cardiograph's TraceMasterVue configuration.	<ol style="list-style-type: none"> <li>1 Check the cardiograph's TraceMasterVue configuration settings.</li> <li>2 Contact the TraceMasterVue system administrator for information.</li> </ol>
<b>Invalid Default Gateway</b> message	Incorrect default gateway specified in the cardiograph's TraceMasterVue configuration.	<ol style="list-style-type: none"> <li>1 Check the cardiograph's TraceMasterVue configuration settings.</li> <li>2 Contact the TraceMasterVue system administrator for information.</li> </ol>
<b>Invalid Primary WINS</b> message	Incorrect Primary WINS specified in the cardiograph's TraceMasterVue configuration.	<ol style="list-style-type: none"> <li>1 Check the cardiograph's TraceMasterVue configuration settings.</li> <li>2 Contact the TraceMasterVue system administrator for information.</li> </ol>
<b>Invalid Primary DNS</b> message	Incorrect Primary DNS specified in the cardiograph's TraceMasterVue configuration.	<ol style="list-style-type: none"> <li>1 Check the cardiograph's TraceMasterVue configuration settings.</li> <li>2 Contact the TraceMasterVue system administrator for information.</li> </ol>
<b>Invalid directory</b> message	Incorrect directory specified in the cardiograph's TraceMasterVue configuration.	<ol style="list-style-type: none"> <li>1 Check the cardiograph's TraceMasterVue configuration settings.</li> <li>2 Contact the TraceMasterVue system administrator for information.</li> </ol>

## Restarting the Cardiograph

To restart the cardiograph:

- 1 Press the **On/Standby** button for 2-3 seconds to shut down the cardiograph.
- 2 Press the **On/Standby** button again to power on the cardiograph.
- 3 If steps 1 and 2 do not work, press the restart button (rear of cardiograph). See Figure 3-1. After approximately 20 seconds, the PageWriter TC70 software identification screen appears, followed by an audible beep.

**Figure 3-1 Restarting the Cardiograph**

**Restart button  
(Gentle pressure only)**

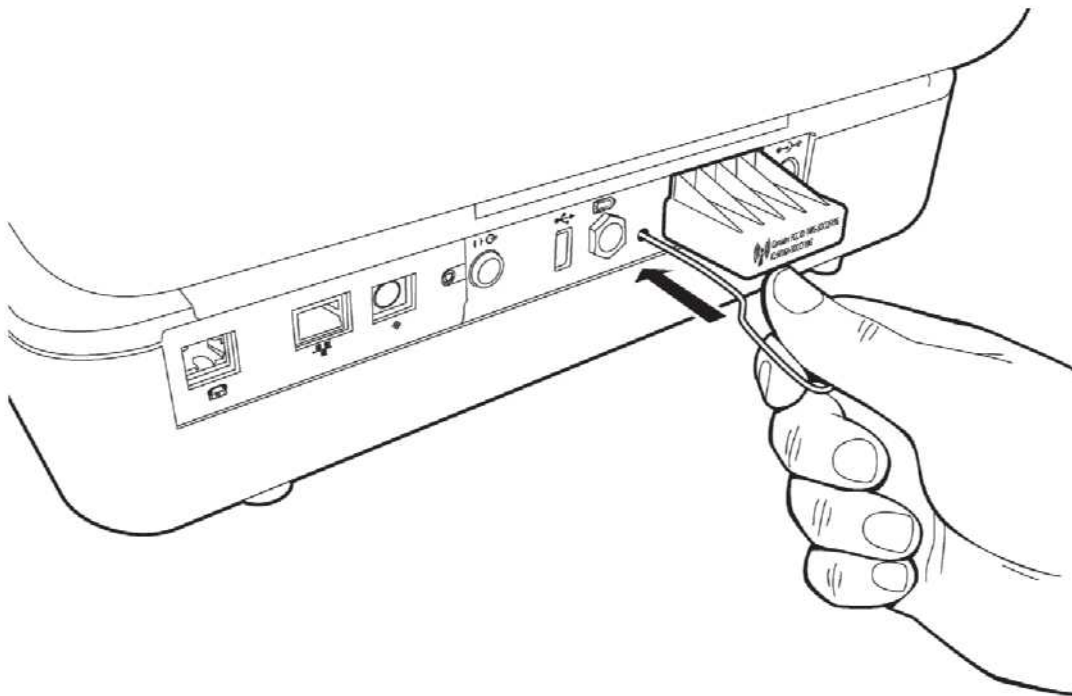

- 4 If steps 1,2, and 3 do not work, remove the batteries and the AC power from the cardiograph.
- 5 Reapply power and repeat steps 1 through 3.

## Running the Lead Wires Open Test

Use the following procedure to test for open lead wires.

### To test for open lead wires

- 1 Connect all of the lead wires to a metallic conductive surface, a shorting bar, or an ECG simulator.
- 2 Touch the **Map** button on the cardiograph's toolbar to open the lead map.
- 3 Ensure that no leads are being reported as leads off (red x mark ) .
- 4 If any of the precordial leads report as leads off, with all limb leads connected, replace the precordial lead(s).
- 5 If all leads report as leads off, replace the RL/N lead with a lead that is known to function normally. If the new lead connected to the RL/N connector functions normally, replace the defective RL lead. Once the RL/N lead is operable, proceed to replace any other leads that display as leads off.

## Running the Lead Wires Short Test

Use the following procedure to test for lead wire shorts.

### To test limb leads

- 1 Disconnect all lead wires from the PIM.
- 2 Disconnect all lead wires from the patient or simulator.
- 3 Connect one limb lead wire to the PIM's **RA** connector. Make sure that the post of the lead wire is not in contact with any other lead wire posts or any other conductive surface.
- 4 Touch the **Map** button on the cardiograph's toolbar to open the lead map.
- 5 Check that the RL lead shows a leads off (red x mark ) .
- 6 If the RA and RL leads show a connection, with all other leads off, then the lead wire in the RA connector has a short.
- 7 Repeat steps 3 through 5, connecting each limb lead (RL, RA, LL, LA) to the PIM's **RA** connector.

### To test chest leads

- 1 Connect all the lead wire to the PIM.
- 2 Connect the limb leads to a metallic conductive surface, shorting bar or an ECG simulator. Do **not** connect the chest leads.
- 3 Touch the **Map** button on the cardiograph's toolbar to open the lead map.
- 4 Check that all limb leads show a connection.
- 5 Verify that all chest leads show leads off (a red x mark ) .
- 6 If any chest leads show a connection, replace that lead wire.

# Running the Service Utilities

The Service Utilities enable you to:

- Obtain information about the cardiograph, such as software versions, installed options, networking information, and battery status.
- Verify and optimize cardiograph performance using the diagnostic tests and utilities



## To run the Service Utilities

- 1 From the Main screen, touch the **Setup** button.  
The Setup and Services main screen appears.

**Figure 3-2 Setup and Services Main screen**

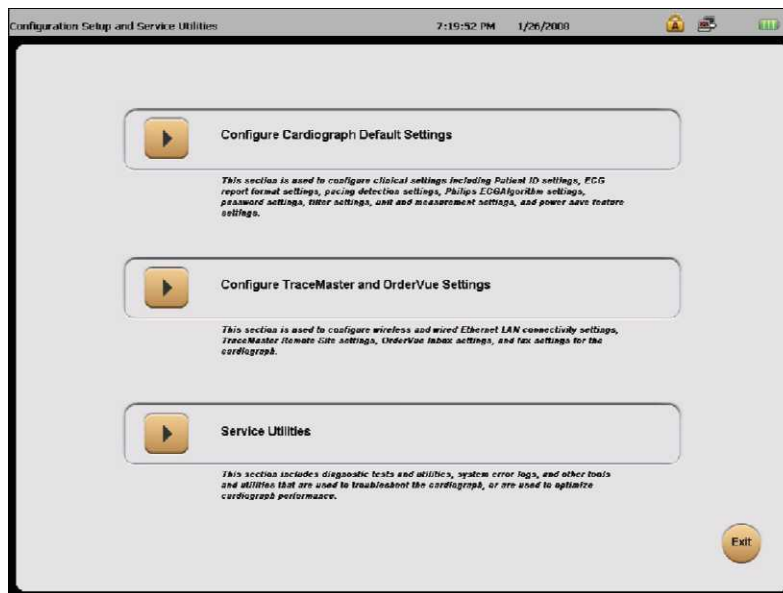

- 2 Touch the button next to **Service Utilities**.  
The Setup and Service Utilities screen appears.

## Using the About the Cardiograph Screen

The About the Cardiograph screen provides important information about the cardiograph that can help in the troubleshooting process. This screen provides information on:

- software revision levels, including application, kernel, and PIM software
- PIM option installed, 12-lead or 16-lead
- networking information such as MAC and IP address
- storage information, such as total RAM, percentage of RAM used, Compact Flash and USB memory stick usage
- battery status, such as capacity, voltage, temperature, percent charged, and cycle count
- voltage monitor information, such as AC/DC input, backlight, and PIM power
- installed options
- total pages printed

### To access the About the Cardiograph screen

- ▶ From the Setup and Service Utilities screen, touch the **About the Cardiograph** tab.

**Figure 3-3 About the Cardiograph screen**

The screenshot shows the 'About the Cardiograph' screen with the following data:

Software Revisions	
Main Application Revision	A.01.00.12
Kernel Revision	3.12.12000
Application Revision	3.12.12000
PIM Kernel Revision	T.009
FPGA Firmware Revision	1.5.12

Storage Information	
Total RAM	219 MB
Percentage Total RAM Used	20%
Internal CF Card(Free/Total)	997.3 / 999.6 MB
USB Memory Stick(Free/Total)	Not Found

Battery Status		Batt 1 (Frm)	Batt 2 (Bck)
Current Status	No activity	No activity	No activity
Battery Voltage	12.5 V	12.4 V	
Expected Max Error(%)	4%	5%	
Full Capacity(mAh)	7006 mAh	7006 mAh	
Remaining Capacity (mAh)	6965 mAh	6912 mAh	
Percent Charged	99%	98%	
Charge Current	0 mA	0 mA	
Discharge Current	0 mA	0 mA	
Cycle Count	11	20	
Temperature	23	24	

Networking Information	
MAC Address	00-09-5C-01-C2-0F
IP Address	0.0.0.0

Voltage Monitor Information		Volts
AC/DC Input		14.700 v
Backlight		12.053 v
I/O		3.309 v / 5.195 v
PIM Power		5.172 v
CPU Internal Core		1.510 v
Flash Memory Internal Core		1.816 v
FPGA Internal Core		1.494 v

Printer Information	
Total Number of Printed Pages	278

Additional fields on the screen include: PIM Information (Installed PIM Option: Triton 16-lead), Unique IDs (B1: EONEMOLT:0013R3-20070529-0012, B2: EONEMOLT:0013R3-20070214-002S), and an Exit button.

### To refresh the screen

- ▶ Touch the **Refresh** button to get the latest information.

**To print the screen**

- ▶ Touch the **Print** button to obtain a printout of the information.

**Running the Diagnostic Tests and Utilities**

The Diagnostic Tests and Utilities help you to troubleshoot issues with the cardiograph. There are two level of tests.

- Maintenance Tests – used to verify or to optimize cardiograph performance. These tests can be used as the first step in identifying a technical problem with the cardiograph.
- Diagnostic Tests – used to identify and to troubleshoot a technical problem with the cardiograph and require a password to access.

All test results are entered in the Event log that is displayed on the screen. Additionally, you can save all log files to a USB memory stick. (See “Viewing and Saving Log Files” on page 3-46 for information on log files.)

**To access the Diagnostic Tests and Utilities screen**

- ▶ From the Setup and Service Utilities screen, touch the **Diagnostic and Test Utilities** tab.

**Figure 3-4 Diagnostic and Tests Utilities screen**

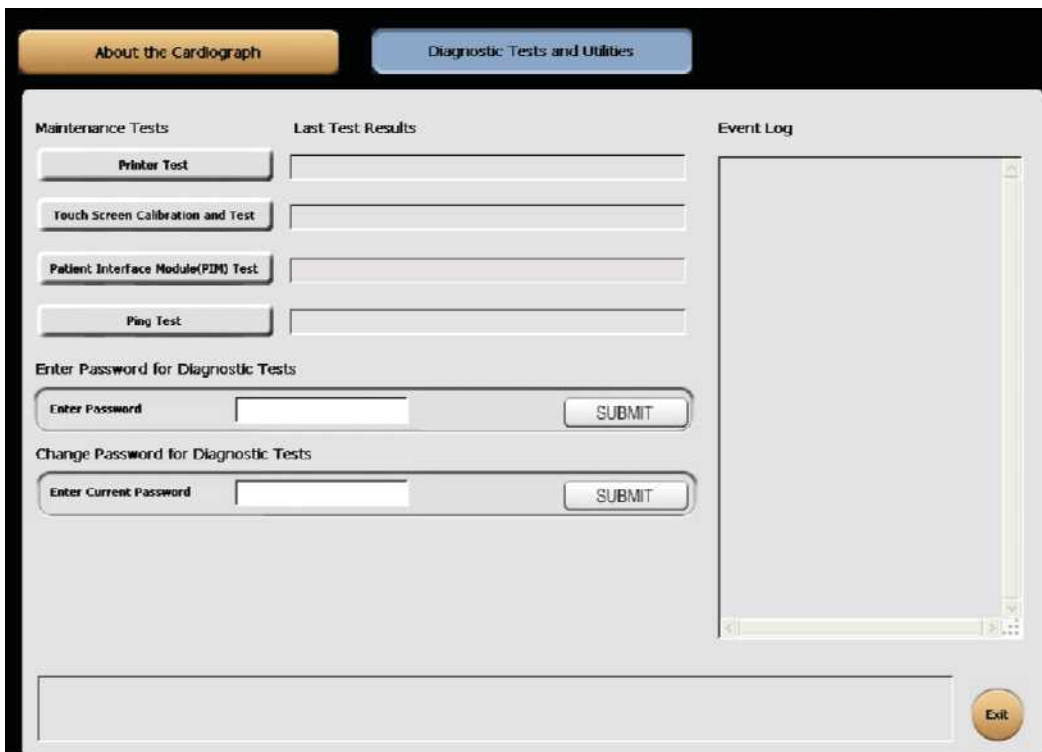

The **Maintenance** section of the screen lists the four maintenance tests.

Test	Page
Printer	3-39
Touch Screen and Calibration	3-41
PIM	3-43
Ping	3-43

### Printer Test

The Printer Test is used to verify that the cardiograph printer is able to correctly print the test page. Use this test to verify proper printer performance or when reports appear to have print quality errors.

#### To perform the Printer test

- 1 Touch the **Printer Test** button.  
The message **Printing Test Page...** appears and the test page prints out.
- 2 Review the printer test page at points A, B, C, and D as shown on Figure 3-5.

Test Point	Description
A	The stepped bars are sharp edged and printed cleanly without distortion or missing segments
B	The spacing between the vertical lines is 25 mm with a discrepancy of no more or less than 2%
C	The diagonal lines should be straight and printed cleanly without distortion or breaks in the lines
D	The character set is printed cleanly without distortion or missing characters, and all characters are clearly legible





## Touch Screen Calibration and Test

The touch screen can be calibrated at any time. Calibration is recommended if it requires many attempts to select an item on the screen, or if selecting items on a specific area of the screen is difficult.

The touch screen may also require calibration if the cardiograph is used in different settings (seated instead of standing) or by users of significantly different height. The touch screen may need to be recalibrated to work optimally in the new setting or with the new user. The Touch Screen Calibration procedures and tests include:

- Force Calibration procedure
- Touch Calibration test

Recommended use of these procedures and tests for maintenance and diagnostic purposes is described in the following table.

**Table 3-15 Touch Calibration Test Recommendations**

Procedure or Test	Recommended Use...
Force Calibration Procedure	<ul style="list-style-type: none"> <li>■ Routine touch screen calibration when the cardiograph is used in a different setting (seated or standing) or by users of significantly different height</li> <li>■ To improve overall touch screen performance when items on the touch screen are difficult to select</li> </ul>
Touch Calibration Test	<ul style="list-style-type: none"> <li>■ Perform this test after performing the Force Calibration procedure</li> <li>■ When calibration is not improved after the Force Calibration procedure (that is, items are still difficult to select on the touch screen)</li> <li>■ When any part of the touch screen appears unresponsive</li> <li>■ When the results of the touch screen calibration need to be reviewed by Philips Response Center representatives to identify a technical problem</li> </ul>

**To access the calibration and test touch screen:**

- ▶ Touch the **Touch Screen Calibration and Test** button.

A screen appears with the following choices:

- Force Calibration
- Start Test
- Done

**NOTE** An error message *Test Calibration Test Failed* appears if you enter the Touch Screen Calibration test screen and exit before running any of the tests or if the Force Calibration procedure is performed without the Touch Calibration test. Touch **Close** to dismiss the message.

**To calibrate the touch screen with the Force Calibration procedure**

- 1 Touch **Force Calibration**.

A white screen appears with a cross hair.

**NOTE** You can also touch the **Ctrl + Alt + C** keys (on keyboard) at the same time from any screen to run the calibration procedure.

- 2 Touch the middle of the cross hair where the two lines intersect.

When the cross hair is touched it moves to a new location. Continue to touch the center of the cross hair.

**NOTE** If it takes several attempts to touch the center of the cross hair, press the ESC key (on keyboard) to close the screen and run the Touch Calibration test.

When the procedure is complete, the message *New calibration settings have been measured*. Press the Enter key to accept the new settings. Press the Esc key to keep the old settings.

- 3 Press the Enter key (on keyboard) to accept the settings.
- 4 Proceed with the Touch Calibration test.

**To calibrate the touch screen with the Touch Calibration test**

- 1 Touch **Start Test**.

A series of blue dots appear on the screen with cross hairs (middle of each circle).

- 2 Touch the center of each cross hair in each circle.

A selected circle turns yellow.

- 3 Touch each circle on the screen.

- 4 When all circles are yellow, touch **Done**.

A message appears indicating that the touch screen calibration failed or passed. If the message *Touch Calibration Test Failed* appears, contact the Philips Response Center.

- 5 Touch **Close**.

## Patient Interface Module (PIM) Test

This test is used to confirm that the Patient Interface Module (PIM) is communicating with the cardiograph. This test can be performed when the cardiograph displays PIM error messages, or when the cardiograph is unable to acquire data from the PIM. Be sure that the PIM patient data cable is securely attached to the PIM connector on the rear of the cardiograph before performing the test.

If this test fails, it may indicate a problem with the PIM or with the PIM patient data cable.

### To perform the PIM Test

- 1 Touch the **Patient Interface Module (PIM) Test** button.  
If the message **PIM Test Passed** appears, the PIM is communicating properly with the cardiograph.
- 2 Touch the **Close** button to close the window.
- 3 If the message **PIM Test Failed** appears, check that the PIM patient data cable is securely attached to the PIM connector on the rear of the cardiograph. If the error message persists, contact the Philips Response Center for assistance, see “Contacting a Philips Response Center” on page 6-11.

## Ping Test

This test is used to test or troubleshoot a network connection between the cardiograph and another device or system, such as a TraceMaster ECG Management System.

### To perform the Ping test:

- 1 Touch **Ping Test**.
- 2 Enter the IP Address to Ping. A message reports if the ping was successful.

## Running the Diagnostic Tests

More comprehensive diagnostic tests and operating statistics are provided in the Diagnostic Tests. These tests are used to identify and to troubleshoot a technical problem with the cardiograph and require a password to access. All test results are entered in the Event log that is displayed on the screen. Additionally, you can save all log files to a USB memory stick. (See “Viewing and Saving Log Files” on page 3-46 for information on log files.)

The following tests are available on the Diagnostic Tests menu.

**Table 3-16 Diagnostic Tests**

Test	Page
Flash Memory	3-44
Internal Compact Flash	3-45
Audio	3-45
Keyboard/Hardware Key	3-45

**To access the Diagnostic Test screen**

- 1 From the Main screen, touch the **Setup** button.  
The Setup and Services main screen appears.
- 2 From the Setup and Service Utilities screen, touch the **Diagnostic and Test Utilities** screen.
- 3 Use the **Tab** key on the keyboard to move the cursor to the Enter Password field.
- 4 Use the keyboard to enter the password (000000) for Diagnostic Tests and touch the **Submit** button.  
The Diagnostic Test screen appears.

**Figure 3-6 Diagnostic Test screen**

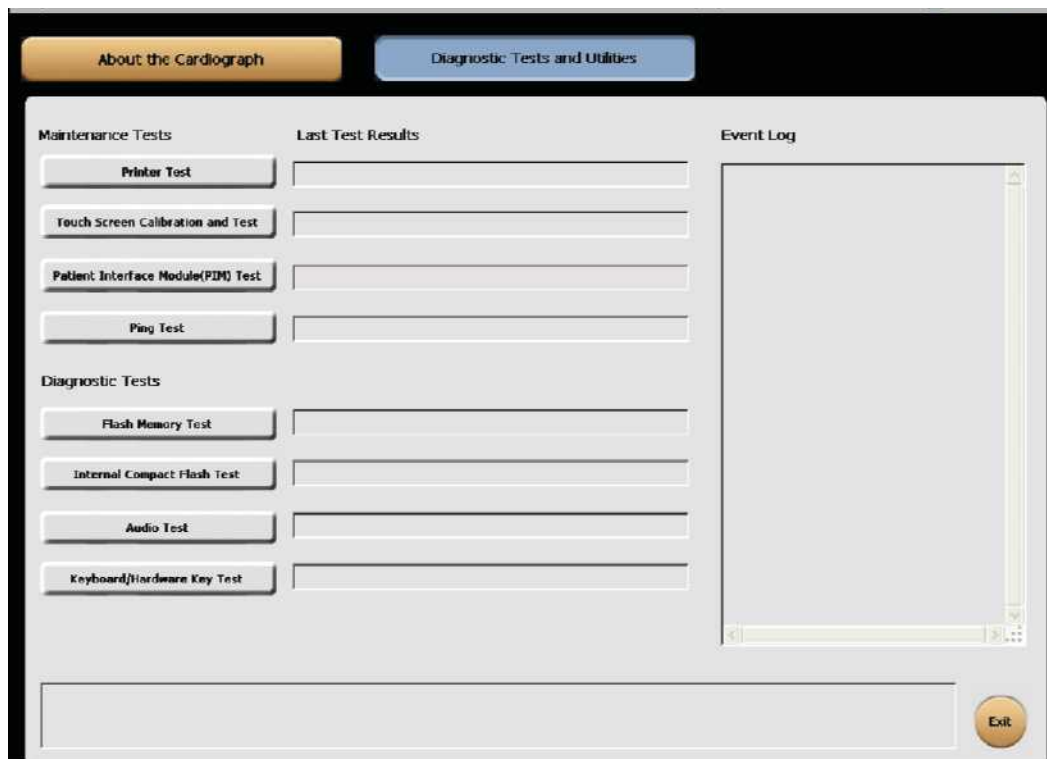

**Flash Memory Test**

This test verifies that the onboard Flash memory is working properly.

**To test the onboard Flash memory**

- 1 Touch the **Flash Memory Test** button.  
A message lets you know if the onboard Flash memory passed the test.
- 2 Select **Close**.  
If the onboard flash card fails the test, try the test again.

## Internal Compact Flash Test

This test verifies that the internal Compact Flash is working properly.

### To test the Internal Compact Flash

- 1 Touch the **Internal Compact Flash** button.  
A message lets you know if the Internal Compact Flash passed the test.
- 2 Touch the **Close** button.  
If the compact flash card fails the test, try the test again.

## Audio Test

This test determines whether the cardiograph is emitting sounds.

### To test audio

- 1 Touch the **Audio** button from the list.  
The test emits audible chime tones.
- 2 Select **Yes** when you see the message **Did you hear the sound playing?**  
A message lets you know that the audio test passed.
- 3 Select **No** if you did not hear the sound playing.  
A message lets you know that the audio test fails.
- 4 Touch the **Close** button.

## Keyboard/Hardware Key Test

A successful Keyboard test is one in which each key is properly recognized when pressed.

- 1 Touch the **Keyboard/Hardware Key Test** button.  
The Keyboard Test window appears.

**Figure 3-7 Keyboard Test window**

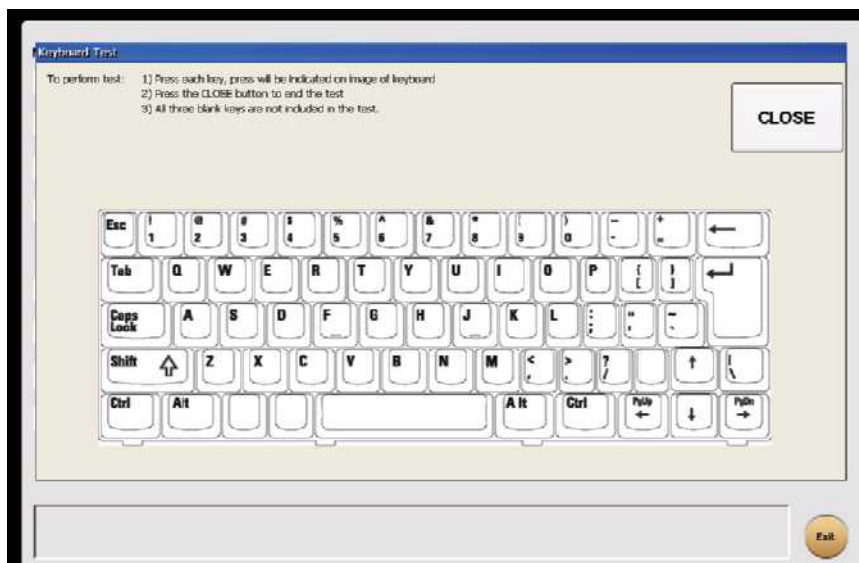

- 2 Press each key on the keyboard. If a key is highlighted, the key is registered.
- 3 After all the keys are highlighted, touch the **Close** button to finish the test.  
A message lets you know if the test passed or failed. The test fails if any of the keys are not recognized when you press them or if you do not press all of the keys.

## Viewing and Saving Log Files

All test results are entered in the Event log that is displayed on the screen. Additionally, you can save all log files to a USB memory stick.

The following example shows the event log on the screen.

**Figure 3-8 Event Log Screen**

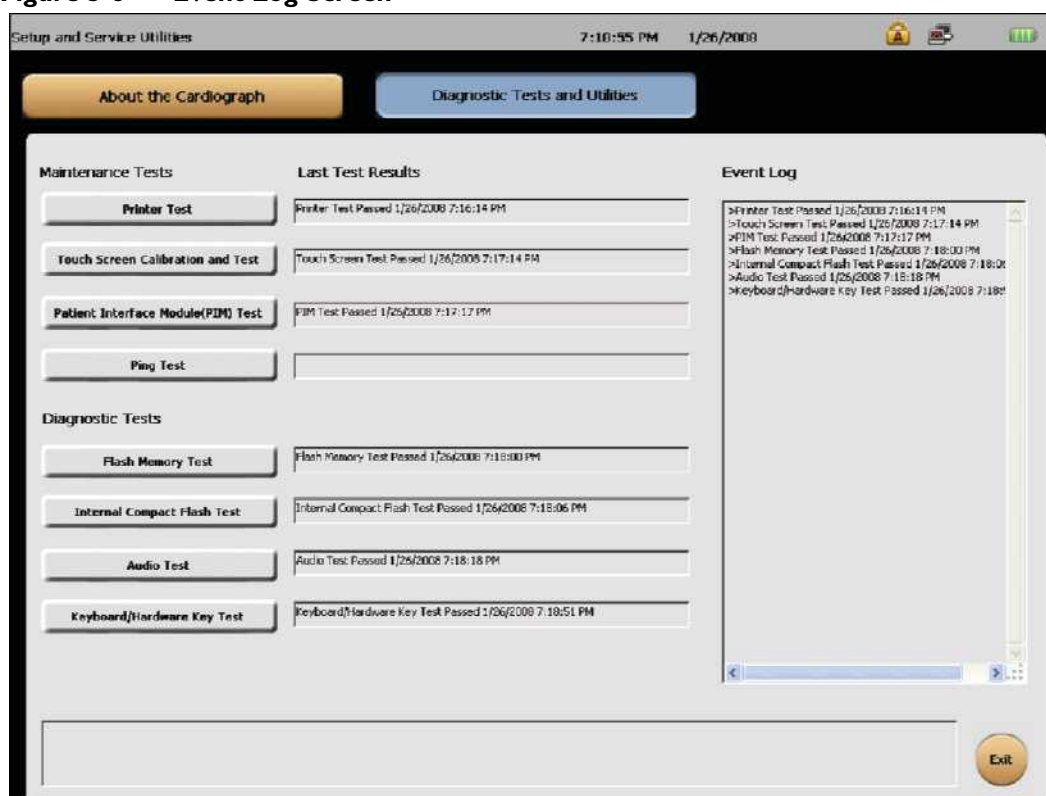

## Saving Log Files

The following log files can be saved to a USB memory stick:

- LOG1.txt
- LOG2.txt
- CFG.xml

These log files can be sent to the Philips Response Center and are useful in troubleshooting cardiograph issues.

### To save log files

- 1 Insert the USB memory stick into the cardiograph.
- 2 From the Setup and Services main screen, touch the button next to **Configure Cardiograph Default Settings**.
- 3 Touch the **Save/Load Settings** button on the Configuration Context Toolbar. The **Save/Load Settings** screen appears.

**Figure 3-9 Save/Load Settings screen**

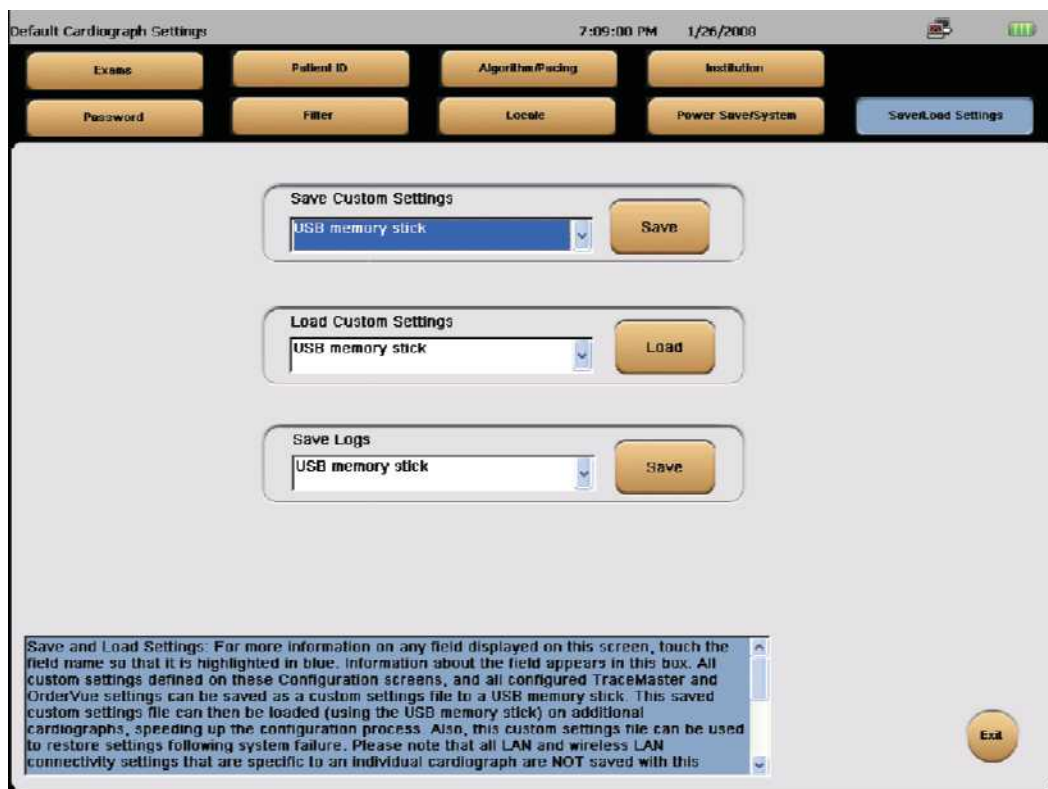

- 4 Under **Save Logs**, make sure that USB memory stick is highlighted.
- 5 Touch the **Save** button.  
The Save Logs screen appears.

**Figure 3-10 Save Logs screen**



- 6 To save the log files to the default file name and location, touch the **Save** button. Proceed to step 10.  
The USB memory stick flashes while the log file is being saved. This can take up to 20 seconds.
- 7 To change the file name or location, touch the **Browse** button.  
The Select file directory screen appears.

**Figure 3-11 Select File Directory screen**

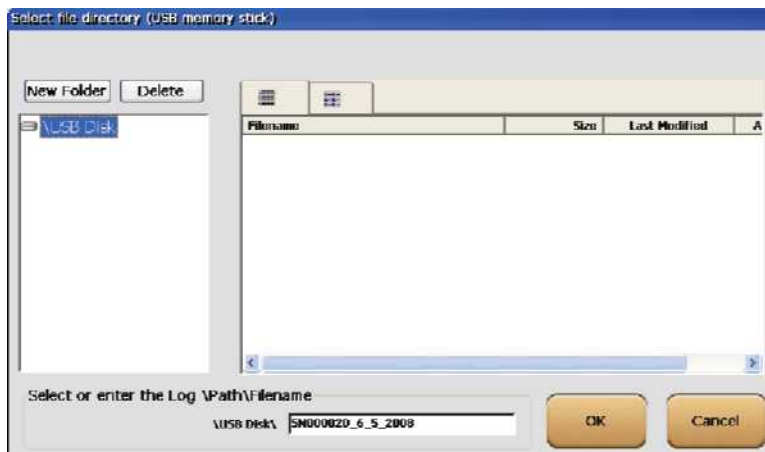

- 8 Touch the **New Folder** button to create a folder for the log files and specify a different file name, if desired. Touch the **OK** button.
- 9 Touch the **Save** button to save the log files to the specified file name and location.  
The USB memory stick flashes while the log file is being saved. This can take up to 20 seconds.
- 10 Remove the USB memory stick when the file save is complete.



# Performance Verification and Safety Tests

This chapter describes the tests and inspections required to verify performance of the PageWriter TC70 cardiograph following a service event.

This chapter provides the following information:

Required Testing Levels. . . . .	4-1
External Repairs. . . . .	4-2
Internal Repairs . . . . .	4-2
Upgrades . . . . .	4-3
Test and Inspection Matrix. . . . .	4-4
Test Equipment . . . . .	4-5
Performance Verification Tests . . . . .	4-6
Visual Inspection (V). . . . .	4-6
Power On Test (PO). . . . .	4-6
Individual Functional Tests . . . . .	4-7
Safety Tests . . . . .	4-12

## Required Testing Levels

The Performance Verification Tests verifies proper operation of the PageWriter TC70 following a service event. The level of testing required corresponds to the type of service performed.

**NOTE** Installation and Preventive Maintenance are not considered service events since the cardiograph is designed to be installed and maintained by the user. Service Events are divided into two categories: Repairs and Upgrades. Repairs are then further divided into External repairs and Internal repairs.

## External Repairs

External repairs consist of repairs or replacements of one or more items. Repair or replacement of these items does not require you to open the cardiograph case, therefore only a limited number of tests are necessary to verify performance post-repair. External repairs that involve the PIM, PIM data cable, and PIM lead set require an ECG simulation test to verify proper ECG signal path.

The typical external repairs include:

- PIM
- Patient Leads
- PIM data cable
- Labels
- Batteries
- Paper Tray
- AC Power Cord
- AC Power Supply
- Wireless LAN card
- USB external devices
- Barcode reader
- Trolley
- External cables

Refer to Table 4-1 for the required test blocks that must be performed after any external repair occurs.

## Internal Repairs

If the case was opened, regardless of the repair, you must perform additional Performance Verification Tests. Refer to Table 4-1 for the required test blocks that must be performed after any internal repair.

# Upgrades

Most PageWriter TC70 upgrades are installed by the user, and are not considered service events. The only exceptions are upgrades for the software and the Magnetic Card Reader. Refer to Table 4-1 for the required test blocks that must be performed after these upgrades.

**Table 4-1 Tests Required**

Service Event		Test Blocks Required
Repairs	External Repairs not involving the patient module (battery, AC power supply, labels, or trolley)	<ol style="list-style-type: none"> <li>1 Visual Inspection</li> <li>2 Power On test</li> <li>3 Functional tests specific to components repaired</li> </ol>
	External repairs where the cardiograph case is not opened, but involving the patient module, patient lead set, or patient data cable	<ol style="list-style-type: none"> <li>1 Visual Inspection</li> <li>2 Power On test</li> <li>3 ECG simulation test</li> <li>4 Functional tests specific to components repaired</li> </ol>
	Internal repairs where the cardiograph case is opened.	<ol style="list-style-type: none"> <li>1 Perform Visual Inspection</li> <li>2 Power On test</li> <li>3 ECG simulation</li> <li>4 Safety tests S2, and S3, plus functional tests specific to components repaired</li> </ol>
Upgrades	Software Upgrades (via USB memory stick)	Power On test

## Test and Inspection Matrix

The following Test and Inspection Matrix describes the various test blocks, expected test results, and what you need to document on the service record.

Test Block Name	Test or Inspection to Perform	Expected (Passing) Test Results	What to Record on a Service Record
Visual Inspection (V)	Perform visual inspection (page 4-6)	If there is no apparent wear, damage, or corrosion the visual inspection passes.	V:P (pass) V:F (fail)
Power On (PO)	<ul style="list-style-type: none"> <li>■ Power on the unit (page 4-6)</li> <li>■ Watch display for errors.</li> <li>■ See the Troubleshooting chapter for a list of errors.</li> </ul>	If the display shows the Software Identification screen followed by the Main screen, the Power On test passes.	PO:P (pass) PO:F (fail)
Individual Functional Tests. The Printer, Touch Screen, PIM and Keyboard tests can be run from within the Service Utilities.			
Printer Test (P)	<ul style="list-style-type: none"> <li>■ Perform Printer Test (page 4-9)</li> </ul>	As described in the test procedure.	P:P (pass) P:F (fail)
Touch Screen Test (TD)	<ul style="list-style-type: none"> <li>■ Perform the Touch Screen Display and Calibration tests (page 4-10)</li> </ul>	As described in the test procedure.	TD:P (pass) TD:F (fail)
PIM Test (PIM)	<ul style="list-style-type: none"> <li>■ Perform the PIM test (page 4-10)</li> </ul>	As described in the test procedure.	PIM:P (pass) PIM:F (fail)
Keyboard Test (K)	<ul style="list-style-type: none"> <li>■ Perform the Keyboard test (page 4-10)</li> </ul>	As described in the test procedure.	K:P (pass) K:F (fail)
Leadwire Test (LW)	<ul style="list-style-type: none"> <li>■ Test leadwires for both open and shorts (page 4-10)</li> </ul>	As described in the test procedure.	LW:P (pass) LW:F (fail)
ECG Simulation (ECG)	<ul style="list-style-type: none"> <li>■ Connect a 12 Lead Patient Simulator to the lead set and print a 12 lead ECG. Visually analyze the printout (page 4-11)</li> </ul>	If there is trace activity in all leads with no notable distortion or noise, and cal pulses of proper duration and amplitude, then the ECG Simulation passes,	ECG:P (pass) ECG:F (fail)

Test Block Name	Test or Inspection to Perform	Expected (Passing) Test Results	What to Record on a Service Record
Safety (S2)	Equipment leakage current (page 4-13)	SF Maximum leakage current $\leq 1000 \text{ uA}$	Example: S2:P/999
Safety (S3)	Leads leakage current (page 4-13) <ul style="list-style-type: none"> <li>■ Source (Normal condition)</li> <li>■ With Mains on applied part (Single Fault Condition)</li> </ul>	$\leq 10 \text{ uA} \quad \text{x1}$ $\leq 50 \text{ uA} \quad \text{x3}$	Example: S3:P/5/20

## Test Equipment

The following test equipment is required to perform the complete set of Performance Verification tests:

- ECG Simulator
- Electrical Safety Tester
- USB memory stick with the most recent PageWriter TC70 software

# Performance Verification Tests

## Visual Inspection (V)

Before beginning the inspection, press the On/Standby button for 2 to 3 seconds to put the cardiograph in Standby mode and unplug the power cord from the wall outlet. Inspect the cardiograph external surfaces for the following:

- Worn or damaged power cord
- Loose or missing hardware
- Mechanical damage
- Evidence of liquid spill
- Worn printer drive gear
- Worn printer roller
- Corroded or damaged reusable electrodes, if present
- Damaged patient leads
- Dirt/paper residue on the thermal print head
- Frayed or damaged wiring
- Visible touch screen damage
- Replace any damaged or missing items.
- Clean the and patient leads as necessary. Cleaning instructions are listed in the Cardiograph Care and Maintenance chapter.

## Power On Test (PO)

Restart the cardiograph to process a completed Power On test.

### To restart the cardiograph:

- 1 Press the **On/Standby** button for 2-3 seconds to shut down the cardiograph.
- 2 Press the **On/Standby** button again to power on the cardiograph.  
After approximately 20 seconds, the PageWriter TC70 software identification screen appears, followed by an audible beep.

The following self-tests are automatically performed during reboot:

- Software CRC Test
- Flash Memory: onboard CompactFlash (CF) and internal CompactFlash (CF)
- PIM Status
- USB Detect

## Individual Functional Tests

You perform the Printer, Touch Screen, PIM, and Keyboard tests using the Service Utilities.

### Accessing the Service Utilities



#### To run the Service Utilities

- 1 From the Main screen, touch the **Setup** button.

The Configuration Setup and Services Utilities main screen appears.

**Figure 4-12 Configuration Setup and Services Main screen**

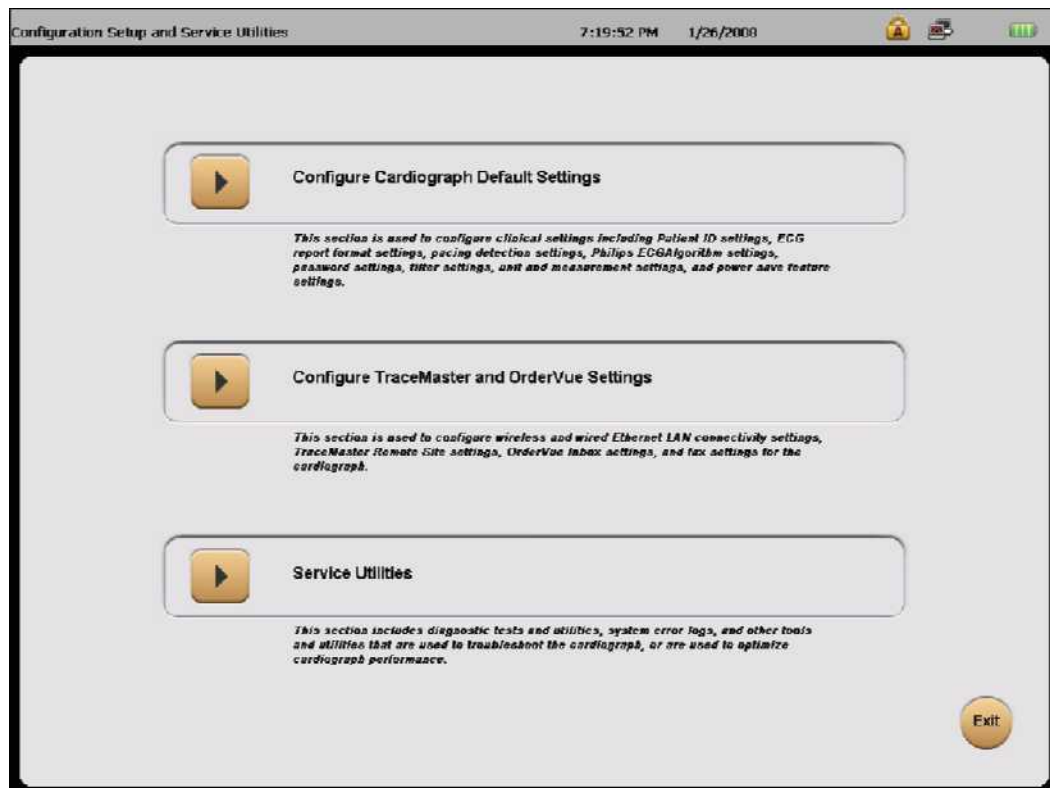

- 2 Touch the button next to **Service Utilities**.

The Setup and Service Utilities screen appears with the About the Cardiograph tab displayed.

Figure 4-13 Setup and Service Utilities About the Cardiograph screen

The screenshot displays the 'About the Cardiograph' screen with the following sections and data:

Software Revisions	
Main Application Revision	4.01.00.12
Kernel Revision	3.12.12000
Application Revision	3.12.12000
PIM Kernel Revision	1.009
FPGA Firmware Revision	1.5.12

Storage Information	
Total RAM	219 MB
Percentage Total RAM Used	20%
Internal CF Card(Free/Total)	907.3 / 999.6 MB
USB Memory Stick(Free/Total)	N/A Found

Battery Status	
Current Status	No activity
Battery Voltage	12.5 V
Expected Max Error(%)	4%
Full Capacity(mAh)	7006 mAh
Remaining Capacity (mAh)	6965 mAh
Percent Charged	99%
Charge Current	0 mA
Discharge Current	0 mA
Cycle Count	11
Temperature	23

Networking Information	
MAC Address	00-09-5C-01-C2-0F
IP Address	0.0.0.0

Voltage Monitor Information	
AC/DC Input	14.700 v
Backlight	12.053 v
I/O	3.309 v / 5.195 v
PIM Power	5.172 v
CPU Internal Core	1.513 v
Flash Memory Internal Core	1.816 v
FPGA Internal Core	1.494 v

Printer Information	
Total Number of Printed Pages	278

Additional fields include: PIM Information (Installed PIM Option: Triton 15-lead), Unique IDs (01: E0A9E9041.E013813-20070529-0012, 02: E0A9E9041.E013813-20070214-0005), and an Exit button.

For detailed information about the components of this screen, see “Using the About the Cardiograph Screen” on page 3-37.

- 3 Touch the **Diagnostic and Test Utilities** tab.



Figure 4-14 Diagnostic and Tests Utilities screen

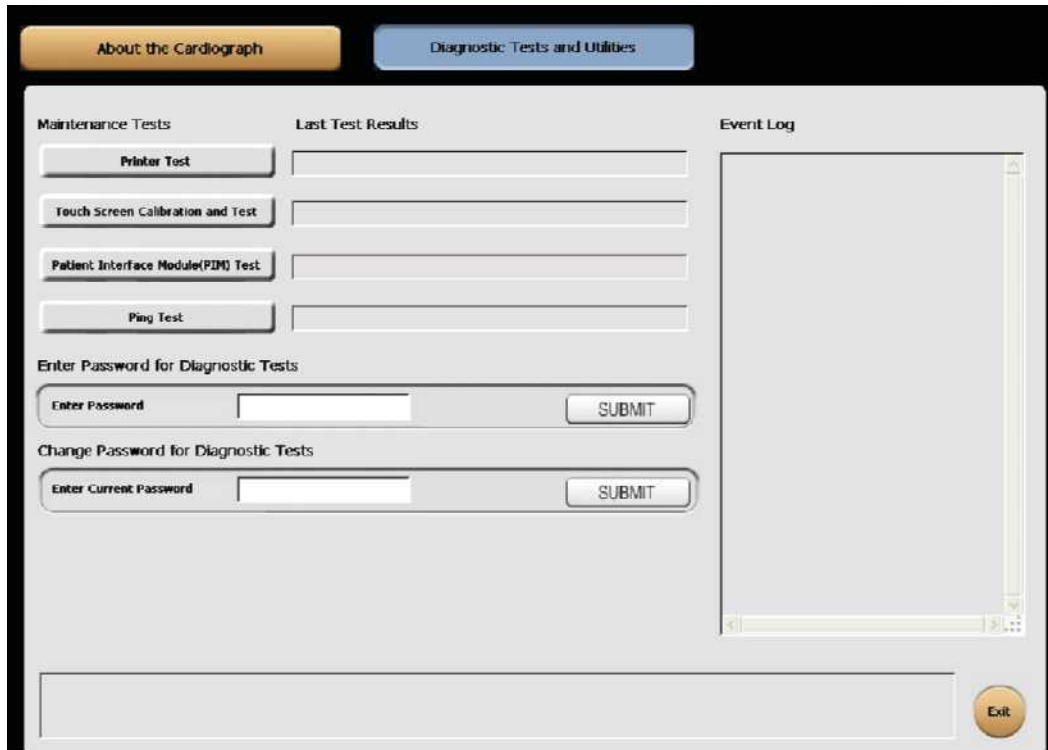

### Printer Test (P)

The Printer Test is used to verify that the cardiograph printer is able to correctly print the test page. Use this test to verify proper printer performance or when reports appear to have print quality errors.

#### To perform the Printer test

- 1 Touch the **Printer Test** button.
- 2 See “Printer Test” on page 3-39 for instructions.

## Touch Screen Display and Calibration Test (TD)

The touch screen can be calibrated at any time. Calibration is recommended if it requires many attempts to select an item on the screen, or if selecting items on a specific area of the screen is difficult.

The touch screen may also require calibration if the cardiograph is used in different settings (seated instead of standing) or by users of significantly different height. The touch screen may need to be recalibrated to work optimally in the new setting or with the new user. The Touch Screen Calibration procedures and tests include:

- Force Calibration procedure
- Touch Calibration test

### To calibrate the touch screen with the Force Calibration procedure

- 1 Touch **Force Calibration**.
- 2 See “Touch Screen Calibration and Test” on page 3-41 for instructions.

### To calibrate the touch screen with the Touch Calibration test

- 1 Touch **Start Test**.
- 2 See “Touch Screen Display and Calibration Test (TD)” on page 4-10 for instructions.

## PIM Test (PIM)

This test is used to confirm that the Patient Interface Module (PIM) is communicating with the cardiograph. This test can be performed when the cardiograph displays PIM error messages, or when the cardiograph is unable to acquire data from the PIM. Be sure that the PIM patient data cable is securely attached to the PIM connector on the rear of the cardiograph before performing the test.

If this test fails, it may indicate a problem with the PIM or with the PIM patient data cable.

### To perform the PIM Test

- 1 Touch the **Patient Interface Module (PIM) Test** button.
- 2 See “PIM Test (PIM)” on page 4-10 for instructions.

## Keyboard Test (K)

A successful Keyboard test is one in which each key is properly recognized when pressed.

- 1 Touch the **Keyboard/Hardware Key Test** button.
- 2 See “Keyboard Test (K)” on page 4-10 for instructions.

## Leadwire Tests (LW)

Run the lead wire open and short tests. See “Running the Lead Wires Open Test” on page 3-35 and “Running the Lead Wires Short Test” on page 3-35 for instructions.

## ECG Simulation (ECG)

Taking an ECG using a 12-lead ECG simulator allows you to verify areas of operation that the extended self-test cannot check:

- Integrity of the patient leads
- Accuracy of the paper speed (not available on all simulators)
- Accuracy of the gain settings (not available on all simulators)

The recorded ECG trace should look similar to the one shown in the following figure. Trace differences may result from differences in simulators, simulator settings, and from differences in configuration and control settings on the cardiograph.

**Figure 4-15 Simulated 12-Lead ECG**

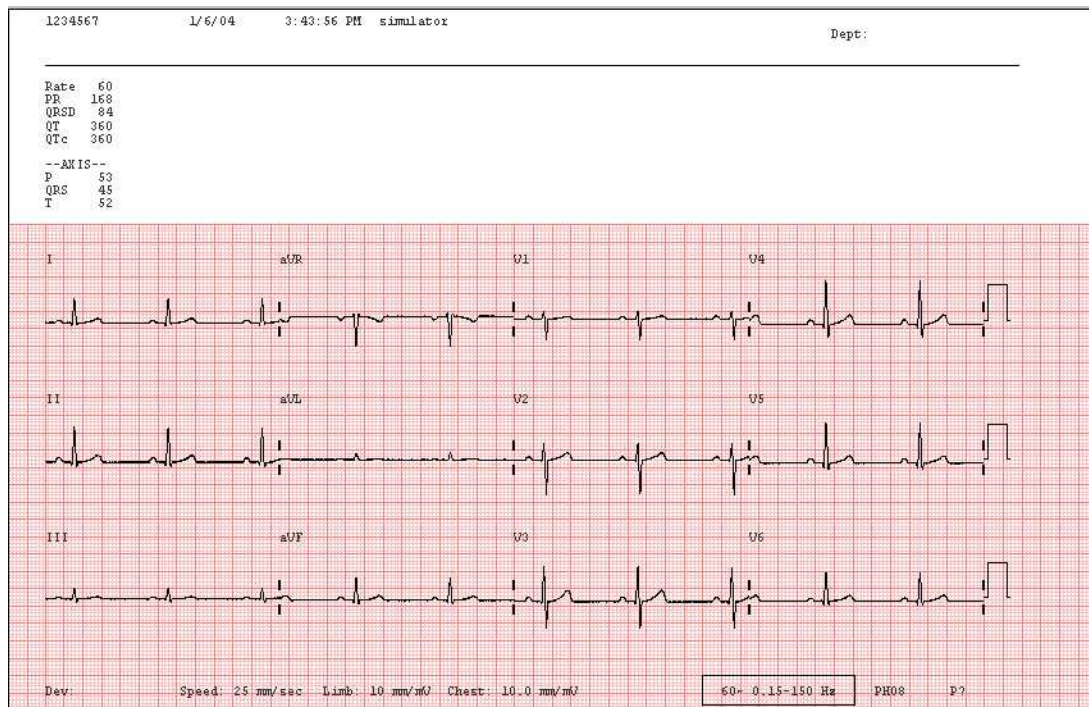

### To make a simulated ECG recording

- 1 Connect the PIM lead wires to the simulator.  
Verify that all lead wires are connected by observing the display for flat lines.
- 2 Touch the **Map** button on the Toolbar.  
Check the leads map to be sure that a red x  does not appear next to any electrodes.
- 3 Firmly pull each lead wire tight, and then look for excessive noise on the display (may be indicated by yellow or orange waveforms).
- 4 Touch the **ECG** button on the toolbar. If a message appears that no patient information has been entered, touch the **Continue** button.  
Depending on how the cardiograph is configured, the ECG may automatically print. If not, touch the **Print** button.

- 5 Verify the following items when printing is complete:
- Trace activity for all leads. Confirms integrity for all patient electrodes and leadwires. Noise should measure less than one (1) mm, with no baseline wander.
  - No gross distortion of complexes or calibration pulses (no overshoot and so forth).
  - Duration for calibration pulses for correct paper speed. With cardiograph set to record at 25 mm/sec, the calibration pulse should measure 5mm (calibration pulse duration is 200 ms).
  - Calibration pulse amplitude is correct.

- NOTES**
- An arrhythmia simulator is not an acceptable tool for verifying computerized ECG analysis. The analysis software is biased to process human ECG data.
  - Noise may be an artifact of poor connections to the simulator or position of the cables. If noise appears, check the connectors or adjust the cable drape.

## Safety Tests

This section covers tests of the cardiograph's electrical safety.

- NOTE** The device is an electrical Class II device in which the protection against electric shock does not rely on basic insulation and a protective earth conductor but on double and/or reinforced insulation.

### Test Notes

- Use the procedures called out by the manufacturer of the safety analyzer in use.
- Test both Normal and Reverse polarity line connections for each test, and record the worst-case value.
- Use the barrel of the PIM connector to connect a test lead to chassis bare metal for the leakage tests.

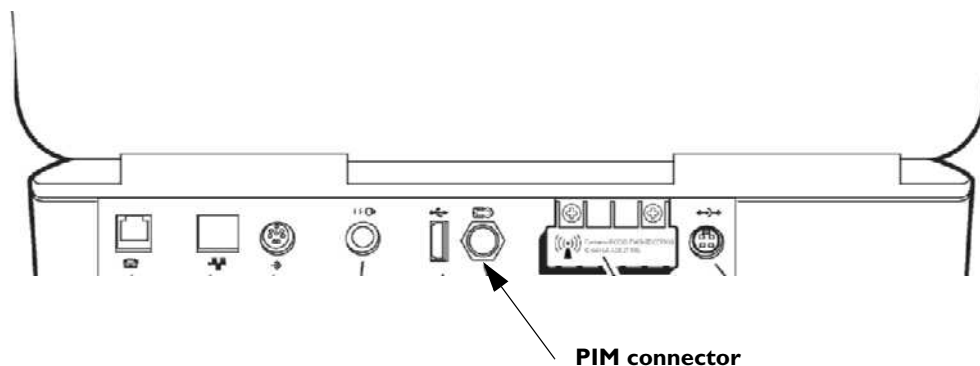

### Safety Test S2 - Equipment Leakage

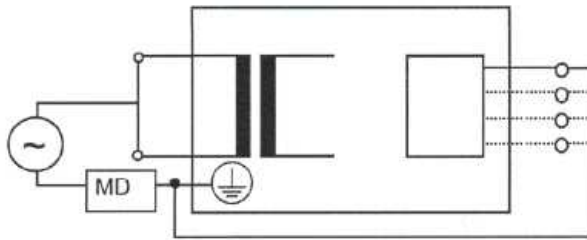

- Applicable to Class 1 and 2, type B, BF, CF. For Class 1: Protective Earth conductor is not connected. S = open. Measure equivalent leakage current to mains part from all Applied Parts and enclosure in parallel. Measures grounded and ungrounded metal parts.
- Maximum leakage current = 1000  $\mu$ A.
- Reference: VDE 0751.

### Safety Test S3 - Leads Leakage Current

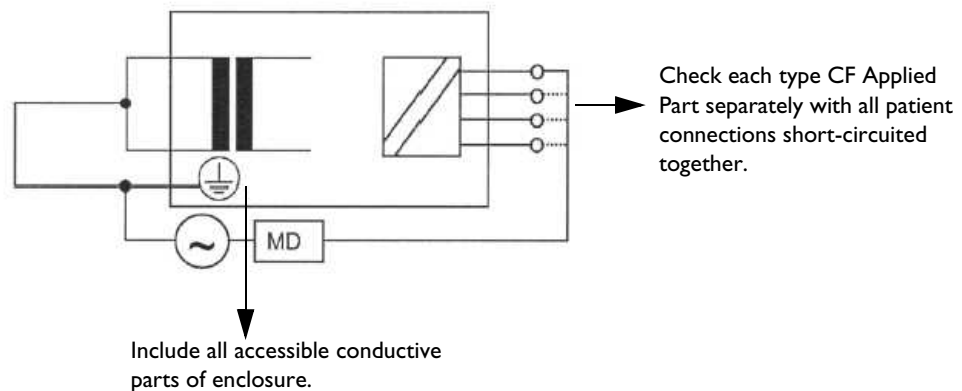

### CF

- Applicable to Class 1 and 2, type CF.
- Measures equivalent leakage current to mains part and enclosure from all Applied Parts in parallel.
- Maximum leakage current CF = 50/100  $\mu$ A. Tested separately (50  $\mu$ A) or together (100  $\mu$ A).



## Parts and Supplies

The part numbers for all replacement parts and supplies for the PageWriter TC70 cardiograph are listed in this section.

This chapter provides the following information:

Ordering Replacement Parts .....	5-1
Replacement Parts .....	5-2
Cart Replacement Parts .....	5-4
Other Replacement Parts .....	5-6
Ordering Supplies .....	5-6
Special Note about Welsh Bulb Electrodes .....	5-6
PageWriter TC70 Cardiograph Supply Part Numbers .....	5-7
Ordering Options and Upgrades .....	5-10
Contacting a Philips Response Center .....	5-11

### Ordering Replacement Parts

To order replacement parts, use prefix number 45.

In the US, call 877-447-7278

Outside the US, contact your local Philips Medical Systems Response Center. See “Contacting a Philips Response Center” on page 5-11.

# Replacement Parts

Figure 5-1 Replacement Parts Exploded Diagram

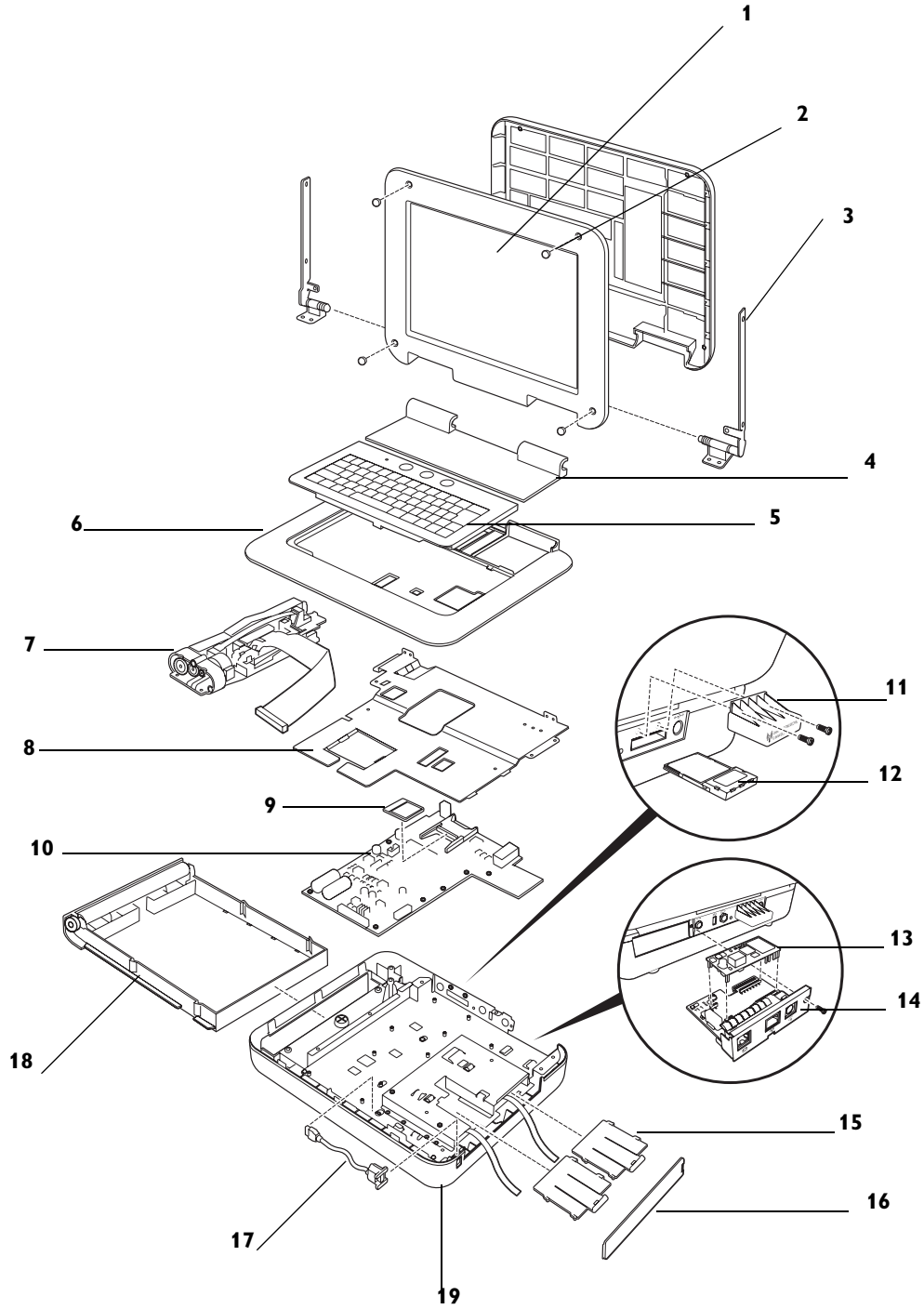

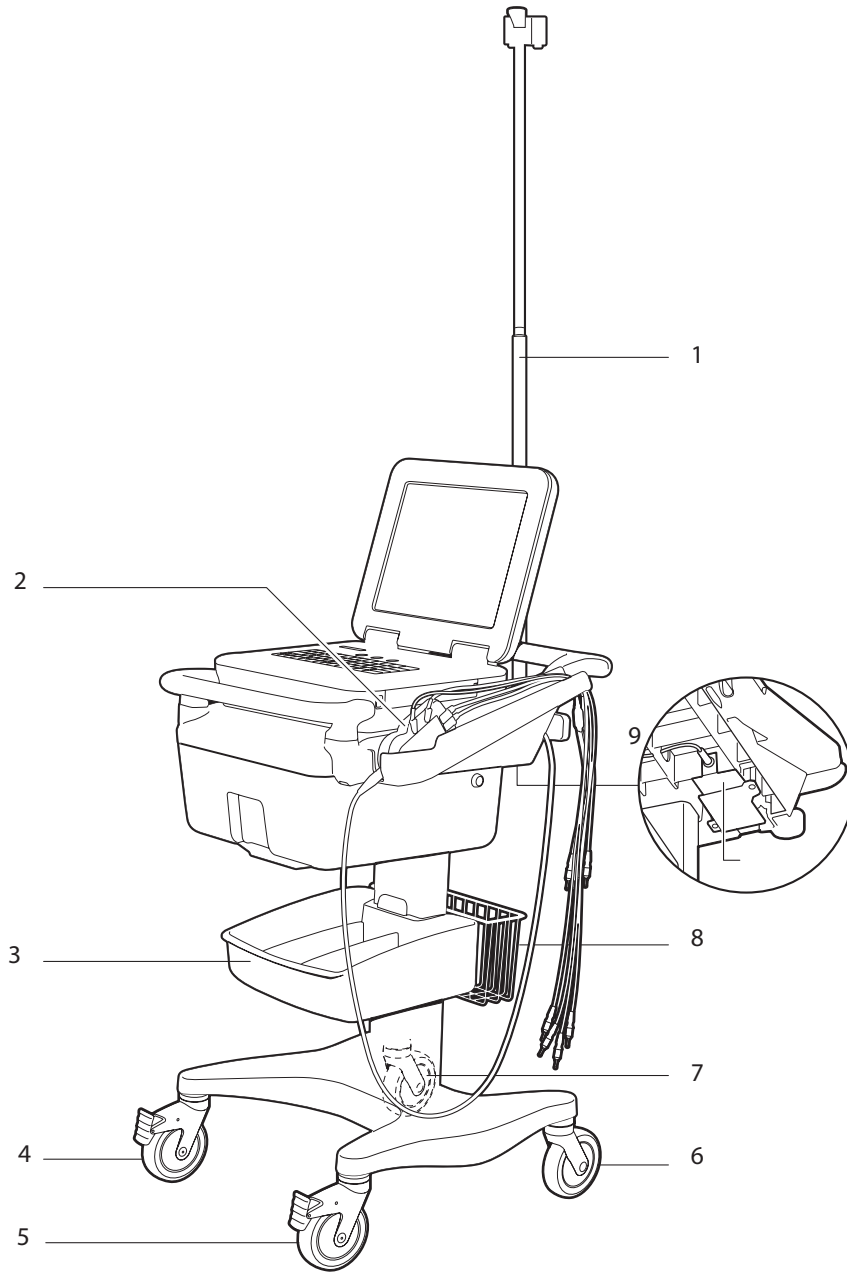

**Table 5-1 Replacement Parts List**

<b>Reference Number</b>	<b>Description</b>	<b>Part Number</b>
1	Display assembly	453564094201
2	Display rubber plugs	453564096481
3	Display hinges	453564124581
4	Hinge cover	453564096421
5	Keyboard assembly English (USA)	453564094281
6	Plastic cover top housing	453564096401
7	Printer assembly	453564110481
8	Metal plate (not a replaceable part, comes with bottom housing kit)	N/A (see reference number 19)
9	Compact Flash memory, 1GB	453563479161
10	Main board	453564094221
11	Wireless LAN Card cover	453564096321
12	Wireless LAN Card	453564096251
13	Modem	453564096241
14	I/O Module	453564096451
15	Battery latch assembly	453564096411
16	Battery door	453564096391
17	Internal USB cable	453564096471
18	Paper drawer assembly A Paper drawer assembly A4	453564096351 453564096361
19	Bottom housing (includes metal plate)	453564096381

# Cart Replacement Parts

Figure 5-2 Cart Parts Exploded Diagram



**Table 5-2 Cart Replacement Parts List**

<b>Reference Number</b>	<b>Description</b>	<b>Part Number</b>
1	989803159011	Patient Cable Arm for Cart
2	453564094241	12-Lead AAMI Patient Interface Module
	453564094251	16-Lead AAMI Patient Interface Module
	453564094261	12-Lead IEC Patient Interface Module
	453564094271	16-Lead IEC Patient Interface Module
3	989803149561	Additional Cart Storage Bin
4	453564054291	Directional locking caster
5	453564054301	Full locking caster
6 and 7	453564050721	Swivel caster
8	989803159001	Additional Wire Basket
9	453564094411	Cart power supply 15V, 80W

## Other Replacement Parts

**Table 5-3**    **Screws**

Part Number	Description
453564119001	Cardiograph to trolley mounting screws and washers (2)
453564096331	Assorted screws consisting of: <ul style="list-style-type: none"> <li>▪ M3 x 8mm T10 (20)</li> <li>▪ M3 x 6mm T10 (2, for I/O board assembly)</li> <li>▪ M4 x 8mm T 20 (6)</li> <li>▪ Display rubber plugs (4)</li> </ul>

## Ordering Supplies

All supplies may be ordered on the web at:

<http://shop.medical.philips.com>

Use the part numbers listed below for reference to ensure that the correct supplies are ordered.

## Special Note about Welsh Bulb Electrodes

**Figure 5-3**    **Welsh Bulb Electrode**



Welsh Bulb electrodes are offered as an optional supply part with the PageWriter TC70 cardiograph. Special care is necessary when using these electrodes. Pay special attention to all warnings associated with these electrodes. For information on cleaning the reusable Welsh Bulb electrodes, see "Reusable Electrode Cleaning" on page 6-4. Philips Medical Systems recommends the use of disposable electrodes with the PageWriter TC70 cardiograph.

---

**WARNING**    **The Welsh bulb electrodes (available as an accessory for the cardiograph) do not meet the requirements of IEC 60601-2-25 for defibrillation recovery time, and cannot be reliably used for patient diagnosis immediately following defibrillation.**

---

**WARNING** Always clean and disinfect reusable electrodes before patient use. See “Reusable Electrode Cleaning” on page 6-4 for information on cleaning and disinfecting reusable electrodes. Failure to properly clean and disinfect reusable electrodes before patient use may cause infectious materials to be transferred between patients.

**CAUTION** The Welsh bulb electrodes contain natural rubber latex which may cause allergic reactions.

## PageWriter TC70 Cardiograph Supply Part Numbers

### PIM Patient Data Cable

Part Number	Description
989803158481	Patient Data Cable (2.0 meters/6.56 feet length)

### Complete Lead Sets

Part Number	Description
989803151631	Complete AAMI Lead Set for Standard 12 Leads (arm lead 99 cm/39 in, leg lead 104.1 cm/41 in, chest leads 69.8 cm/27.5 in)
989803151641	Complete IEC Lead Set for Standard 12 Leads (arm lead 99 cm/39 in, leg lead 104.1 cm/41 in, chest leads 69.8 cm/27.5 in)
989803151711	Complete Limb Lead Set (AAMI/IEC) (arm lead 99 cm/39 in, leg lead 104.1 cm/41 in)
989803151671	Complete Chest Lead Set (AAMI/IEC) (chest leads 69.8 cm/27.5 in)
989803151651	Long Complete AAMI Lead Set for Standard 12 Leads (arm lead 137.1cm/54 in, leg lead 142.2 cm/56 in, chest leads 69.8 cm/27.5 in)
989803151661	Long Complete IEC Lead Set for Standard 12 Leads (arm lead 137.1cm/54 in, leg lead 142.2 cm/56 in, chest leads 106.6 cm/42 in)
989803151731	Long Limb Lead Set (AAMI and IEC) (arm lead 137.1cm/54 in, leg lead 142.2 cm/56 in)
989803151691	Long Complete (Limb and Chest) Lead Set (AAMI and IEC) (arm lead 137.1cm/54 in, leg lead 142.2 cm/56 in, chest leads 106.6 cm/42 in)
989803151691	Long Chest Lead Set (AAMI/IEC) (chest leads 106.6 cm/42 in)

**Complete Lead Sets** *(continued)*

<b>Part Number</b>	<b>Description</b>
989803151751	Complete AAMI Lead Set for 16 Leads (arm lead 99 cm/39 in, leg lead 104.1 cm/41 in, chest leads 69.8 cm/27.5 in, extended leads 83.8 cm/33 in)
989803151761	Complete IEC Lead Set for 16 Leads (arm lead 99 cm/39 in, leg lead 104.1 cm/41 in, chest leads 69.8 cm/27.5 in, extended leads 83.8 cm/33 in)
989803151771	Long Complete AAMI Lead Set for 16 Leads (arm lead 137.1cm/54 in, leg lead 142.21 cm/56 in, chest leads 106.6cm/42 in, extended leads 121.9cm/48 in)
989803151781	Long Complete IEC Lead Set for 16 Leads (arm lead 137.1cm/54 in, leg lead 142.21 cm/56 in, chest leads 106.6cm/42 in, extended leads 121.9cm/48 in)

**Lead Accessories**

<b>Part Number</b>	<b>Description</b>
989803129231	Alligator Clips for Disposable Tab Electrodes (AAMI) (10 total per pack)
989803129241	Alligator Clips for Disposable Tab Electrodes (IEC) (10 total per pack)
989803101361	Alligator Clip Extender (Pediatric) for Disposable Tab Electrodes (10 total per pack) (AAMI)
989803101371	Alligator Clip Extender (Pediatric) for Disposable Tab Electrodes (10 total in pack) (IEC)
989803106061	Wide Disposable Tab Electrode Connector (10 total per pack) (AAMI/IEC)
989803101701	IEC Snap Lead Adapter (converts IEC connector to grabber connector for use with snap disposable electrodes and 4mm banana plug termination cables)
989803151701	16-Lead Spare Parts Kit (includes color rings, shorting plugs, lead separators and banana post adapters)

**Disposable and Reusable Electrodes**

<b>Part Number</b>	<b>Description</b>
989803100441	Solid gel tab disposable cardiography electrode, resting diagnostic ECG (35 mm x 22 mm, 1.37 x .86 in) (1000 total electrodes)

**Disposable and Reusable Electrodes** *(continued)*

<b>Part Number</b>	<b>Description</b>
989803106051	Solid gel tab disposable cardiography electrode, resting diagnostic ECG (33 mm x 20 mm, 1.29 x .78 in) (1000 total electrodes)
989803149901	Pediatric disposable tab electrode (14 mm x 34 mm, .55 x 1.33 in) (1000 total electrodes)
989803101311	Reusable Welsh Bulb Electrode 15 mm diameter (AAMI) (6 total electrodes)
989803101651	Reusable Welsh Bulb Electrode 15 mm diameter (IEC) with banana plug adapter (1 total electrode)
989803101281	Reusable Welsh Bulb Electrode (IEC) with side screw connection (6 total electrodes)
989803101661	Reusable Adult Limb Plate Electrode (IEC) (4 total electrodes)
989803101691	Reusable Adult Limb Clamp Electrode (4 total electrodes) (AAMI/IEC)
989803101341	Reusable Adult Limb Plate Electrode for push-in type connection, nickel-silver (4 total electrodes) (AAMI/IEC)
989803100601	Rubber Strap for Reusable Limb Plate Electrodes (38 cm/15 in) (4 total straps) (AAMI/IEC)

**Printer Paper**

<b>Part Number</b>	<b>Description</b>
989803106261	Z-fold, with header, A size (8.5 x 11 in/21.6 x 28 cm)
989803106271	Z-fold, with header, A4 size (8.27 x 11.69 in/21 x 29.69 cm)
989803106281	Anti-fade, A size (8.5 x 11 in/21.6 x 28 cm)
989803106291	Anti-fade, A4 size (8.27 x 11.69 in/21 x 29.69 cm)

**Batteries**

<b>Part Number</b>	<b>Description</b>
989803160981	Lithium-ion replacement battery (2 batteries are required to power the cardiograph)
989803162021	External Battery Charger (used to charge and to calibrate batteries)

## Ordering Options and Upgrades

For more information on ordering any of the following cardiograph upgrades or options, please contact your Philips Sales Representative or your local distributor.

**Table 5-4 Data Input Options**

Option Ordering Number	Description
860315, with option H12	Barcode Reader
860315, with option H13	Magnetic Card Reader
860315, with option H14	Smart Card Reader
989803161021	USB Memory Stick

**Table 5-5 Patient Interface Module (PIM) Options**

Upgrade Number	Description
860315, with option H21	12-Lead Patient Interface Module (PIM) (AAMI or IEC)
860315, with option H22	16-Lead Patient Interface Module (PIM) (AAMI or IEC)

**Table 5-6 Upgrade Kits**

Upgrade Number	Description
860315, with option D21	Wireless LAN Upgrade Kit
860315, with option H11	Global Modem Upgrade Kit

**Table 5-7 Cardiograph Cart Accessories**

Upgrade Number	Description
860318, with option B01	Partially Assembled Cardiograph Cart
860318, with option B02	Fully Assembled Cardiograph Cart



## Contacting a Philips Response Center

The Philips Response Center can assist with product troubleshooting and provide technical expertise to help with any issue with the PageWriter TC70 cardiograph or any of its accessories.

For more information on the Philips Response Center go to:

[www.medical.philips.com/main/services/response\\_center](http://www.medical.philips.com/main/services/response_center)

### North America Response Centers

Country	Telephone Number
Canada	(800) 323 2280
Mexico	01 800 710 8128
Puerto Rico	1 787 754 6811
United States	(800) 722 9377

### South America Response Centers

Country	Telephone Number
Argentina	54 11 4546 7698
Brazil	0800 701 7789
Chile	0800 22 3003
Columbia	01 8000 11 10 10
Peru	51 1 620 6440

### Europe Response Centers

Country	Telephone Number
United Kingdom	44 0870 532 9741 Fax: 44 01737 23 0550
Austria	43 1 60101 820
Belgium	32 2 525 7102 (French) 32 2 525 7103 (Flemish)
Czech Republic MCR Response Center (located in The Netherlands)	31 40 2781619
Denmark	45 80 30 30 35

**Europe Response Centers** *(continued)*

<b>Country</b>	<b>Telephone Number</b>
Finland	358 615 80 400
France	0 810 835 624
Germany	0180 5 47 5000
Greece MCR Response Center (located in The Netherlands)	31 40 2781619
Hungary MCR Response Center (located in The Netherlands)	31 40 2781619
Italy	0800 232100
Netherlands	31 40 27 211 27
Norway	47 800 84 080
Poland MCR Response Center (located in The Netherlands)	31 40 2781619
Rumania MCR Response Center (located in The Netherlands)	31 40 2781619
Russia MCR Response Center (located in The Netherlands)	31 40 2781619
Slovak Republic MCR Response Center (located in The Netherlands)	31 40 2781619
Spain	34 90 230 4050
Sweden	46 200 81 00 10
Switzerland	0800 80 3000 (German) 0800 80 3001 (French)

**Asia Response Centers**

<b>Country</b>	<b>Telephone Number</b>
Australia	1800 251 400
China	800 810 0038
Hong Kong	852 2876 7578
India	1600 112 444
Indonesia	62 21 7910040, ext 8610
Japan	81 (0)120 095 205
Korea	82 (0)2 3445 9010
Malaysia	1800 886 188
New Zealand	0800 251 400
Philippines	63 2 8162617 ext. 875
Singapore	1800 Philips
Taiwan	0800 005 616
Thailand	66 (0)2 614 3569

**Africa and Middle East**

<b>Country</b>	<b>Telephone Number</b>
All countries MCR Response Center (located in The Netherlands)	31 40 2781619



# Installing PageWriter TC 70 Software

A software installation procedure takes approximately fifteen minutes to complete.

This chapter provides the following information:

Software Upgrades . . . . .	6-1
Obtaining Software . . . . .	6-1
Downloading Software Files from Philips InCenter . . . . .	6-1
Installing the Software Upgrade . . . . .	6-3
Verifying the Software Installation . . . . .	6-6

## Software Upgrades

The upgrade path for a specific cardiograph is dependent upon the software version that is currently installed on the unit. Follow the same procedure to upgrade the software in an existing working unit or to install software on a new system.

## Obtaining Software

The software installation procedure requires the use of

- a computer with a USB slot
- internet access
- blank USB memory stick

The following procedure describes how to download the cardiograph software files to the USB memory stick. If the USB memory stick with the applicable software is available, proceed to page 6-3.

## Downloading Software Files from Philips InCenter

All software upgrade files may be downloaded from the Philips InCenter web site found at: [www.incenter.medical.philips.com](http://www.incenter.medical.philips.com). The InCenter site requires an active login and password. Instructions for obtaining a login and password are located on the right side of the main InCenter home page.

**To load the software upgrade files to the USB memory stick:**

- 1 Insert the USB memory stick into a compatible slot on a computer or other device.
- 2 Go to the InCenter site ([incenter.medical.philips.com](http://incenter.medical.philips.com)) and enter your login information.

**NOTE** For information on registering for the InCenter site, see “Using the Philips InCenter Site” on page 1-4.

- 3 On the top menu bar (top of screen), click on **Service**. From the drop-down menu, select **Software**, **Software Downloads**, and then **Diagnostic ECG**. The Diagnostic ECG Software Downloads screen appears.

**Figure 6-4 InCenter Service Menu**



- 4 Select **PageWriter** from the side menu (left side of screen). Then select **PageWriter TC 70**. The PageWriter TC 70 software download screen appears.
- 5 Click the **PageWriter TC 70** link.
- 6 On the following software download screen, click the **PageWriter TC 70** link.

**NOTE** The **Documentation** link contains all user documentation (instructions for use, quick reference cards) for the selected software version.

- 7 The InCenter software download license agreement appears. If you agree to the terms of the agreement, click **I agree**.

**NOTE** A message may appear that the **Download Manager** application needs to be installed. Click as indicated to install the ActiveX control in order to continue with the software download. See the InCenter main page for more information on installing and using ActiveX controls with the InCenter site.

- 8 Select a file destination and then click **Save**. The Philips Download Manager dialog appears. The software files are saved to the specified destination. After the files are saved, click **Launch**. The WinZip Self Extractor dialog appears.
- 9 Select a destination for the files and then click **Unzip**. The files are saved to the specified destination.
- 10 Remove the USB memory stick from the computer or other device and proceed to the next section.

**NOTE** Once you download software to a USB memory stick, the software installation program will run whenever you insert this USB memory stick into a cardiograph. If you want to use this USB memory stick for copying configuration files or saving log files, delete the SYSINT folder after you have installed the software.

# Installing the Software Upgrade

## Before You Begin

- Save configuration data to a USB memory stick. Although data such as custom configurations, archived ECGs, and orders are preserved during the software upgrade, it is recommended that you back up this data to a USB memory stick before upgrading the software.
- Transmit archived ECGs to TraceMasterVue or a USB memory stick before upgrading the software.

### To install the software upgrade:

- 1 Ensure that the Patient Interface Module (PIM) is securely attached to the connector on the rear of the cardiograph.

**Figure 6-5** Connecting the PIM to the cardiograph

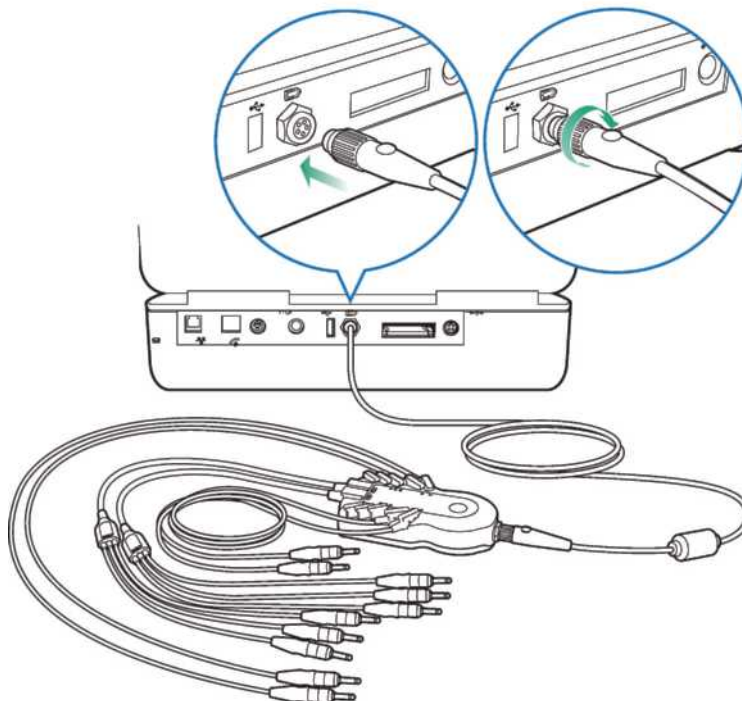

- 2 Insert the USB memory stick into the PC card slot.
- 3 Connect the cardiograph to AC power. Verify that the green LED on the front of the cardiograph is lit.

---

**WARNING** Always connect the cardiograph to AC power when performing the software upgrade. If the cardiograph is not connected to AC power when performing the software upgrade it may be damaged.

---

- 4 Press the On/Off button to turn on the cardiograph.  
The Welcome screen appears.

**Figure 6-6 Software Welcome Screen**

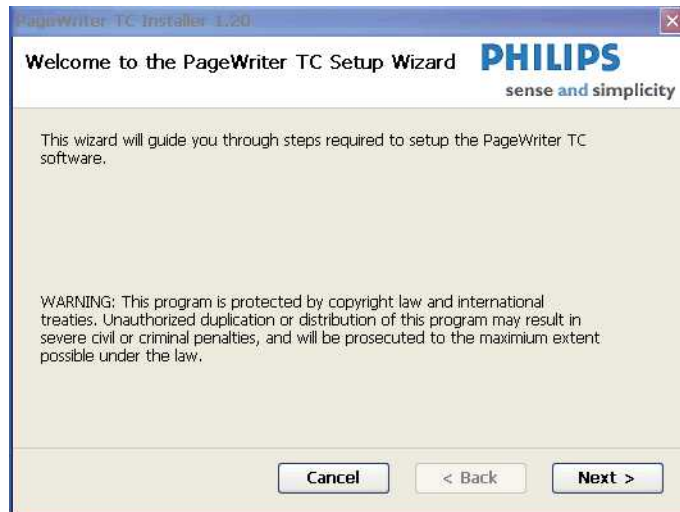

- 5 Touch **Next**.  
A message appears warning you that any unsaved patient information will be lost.
- 6 Touch **Yes** to continue the installation.  
A screen appears informing you that the system is collecting information. Once that process is complete, the Setup Type screen appears.
- 7 Touch **Next** at the Setup Type screen to continue the installation.  
The Choose Setup Options screen appears.

**NOTE** Verify that the serial number on the screen matches the serial number on the rear panel of the cardiograph (USxxxxxxxx). If the serial number is not displayed on the screen or it does not match the serial number on the cardiograph, enter the correct serial number in the Choose Setup Options screen before proceeding.

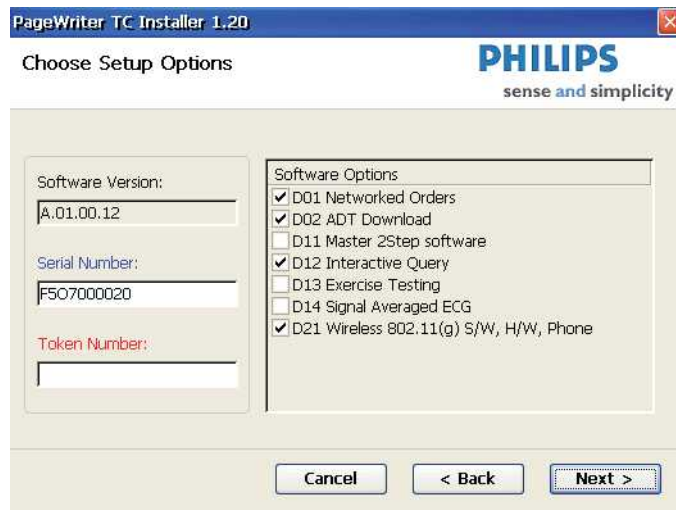

**Figure 6-7 Choose Setup Option Screen**

- 8 Accept the defaults on this screen and touch **Next**.

The Choose software components to install screen appears. The install program compares the information on your cardiograph to the information on the USB memory stick and only checks the components that need to be installed. In most cases, there will be components that are not checked.

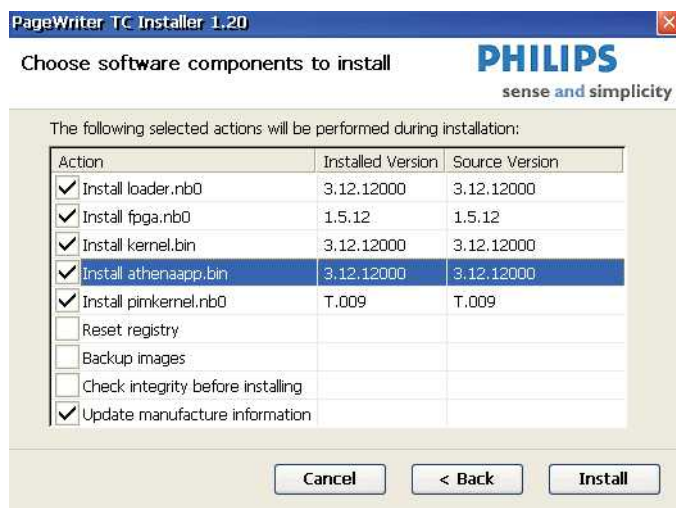
**Figure 6-8 Choose Software Components to Install Screen**

- 9 Accept the defaults on this screen and touch **Install**.

The software installation progress screen appears. When installation is complete, the Installation Complete screen appears prompting you to remove the USB memory stick and restart the cardiograph.

**NOTE** If the cardiograph's registry was updated, you may see a screen stating that the registry will be reset to factory defaults. If so, touch Yes.

**Figure 6-9** Installation Complete Screen

**10** Remove the USB memory stick and touch **Restart**.

## Verifying the Software Installation

Complete the following procedure to verify that the software application has been successfully installed.

**To verify the software installation is complete:**

- 1 From the cardiograph main screen, touch the **Setup** button.
- 2 Touch the button next to **Service Utilities**.  
The Setup and Service Utilities screen appears.
- 3 Check the following Software Revisions on the About the Cardiograph screen to ensure they are at the correct revisions:
  - Main Application Revision
  - Kernel Revision
  - Application Revision
  - PIM Kernel Revision

**Figure 6-10 Software Revisions**

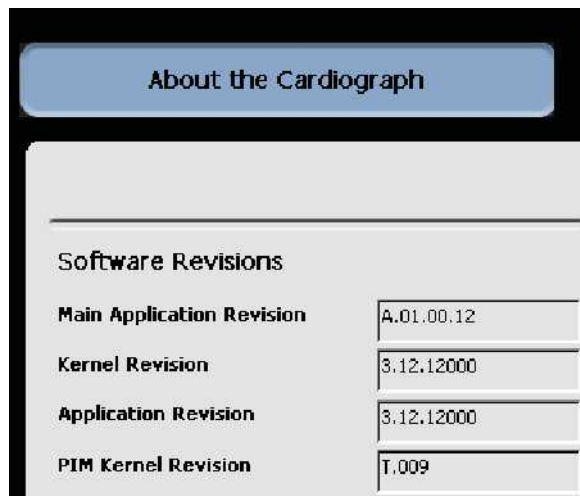



---

## Cart Assembly

Follow the instructions in this chapter to assemble the cart, attach the bin to the cart, and attach the cardiograph to the cart. For information on replacing the rear casters, see the instruction sheet that comes with the replacement kit.

For part ordering information for the replacement kit, see Chapter 6, “Parts and Supplies”.

This chapter provides the following information:

Safety Summary . . . . .	7-3
Safety and Regulatory Symbols Marked on the Cart . . . . .	7-3
Important Patient and Safety Information . . . . .	7-3
Assembling the Cart . . . . .	7-3
Attaching the Cardiograph to the Cart . . . . .	7-6
Attaching Other Cart Accessories and Replacement Parts . . . . .	7-7

Figure 7-1 The PageWriter TC 70 Cardiograph Cart

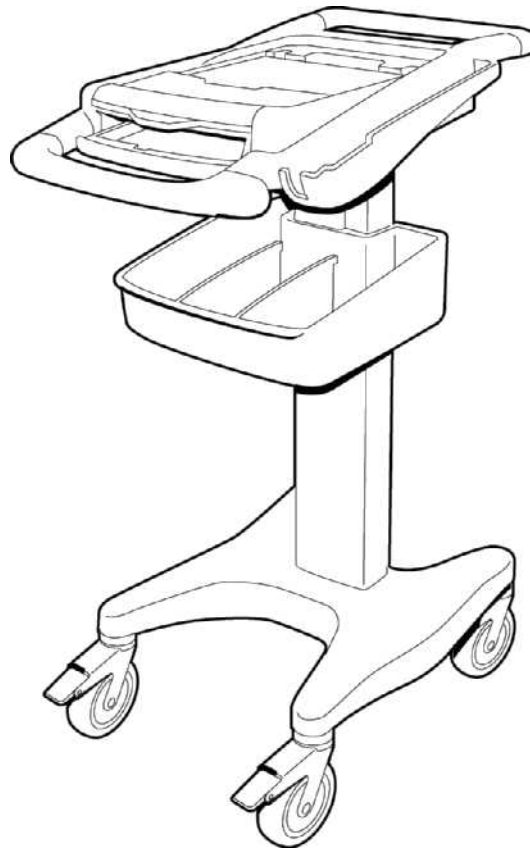
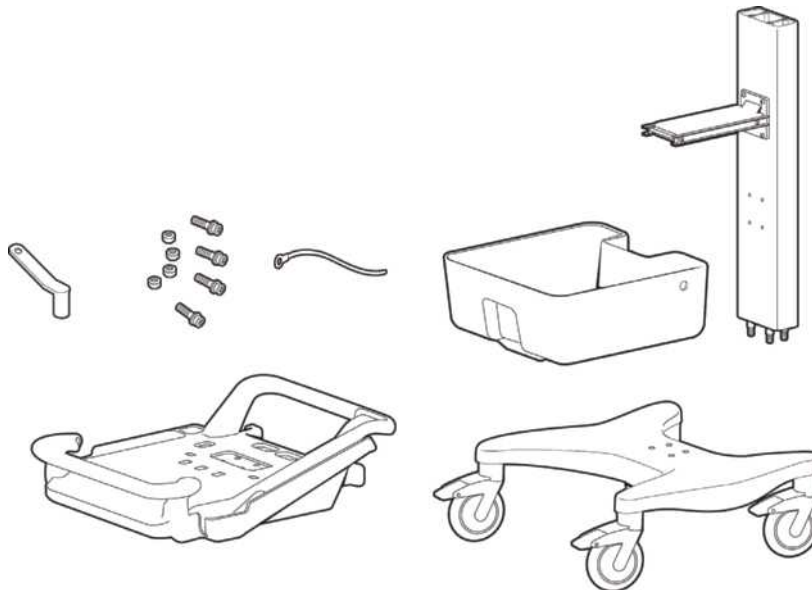



Figure 7-2 Unassembled Cart Kit Contents



## Safety Summary

### Safety and Regulatory Symbols Marked on the Cart

Symbol	Name	Description
	Cart Transport	Use care when moving the cardiograph cart. Pushing the cart over bumps without holding onto the cardiograph may cause the cart to tip.
	Cart Storage Bin Weight Limit	Do not place more than 3 kilograms or 6.6 pounds of weight into the cart storage bin.

### Important Patient and Safety Information

- The combined maximum weight that can be placed on the cardiograph cart shelf and the top surface of the cart cannot exceed 20 kilograms (44 pounds). Do not place more than the specified weight on the cardiograph top surface and shelf.
- Ensure that the patient data cable is tucked away from the cardiograph cart wheels when transporting the cardiograph. Ensure that the patient data cable does not present a hazard when pushing the cardiograph cart.

### Assembling the Cart

The PageWriter TC70 cardiograph is available with an optional cart that includes a storage bin, storage basket, and a built-in holder for the PIM (patient interface module). The instructions in this section describe the unassembled cart option.

**To assemble the cart**

- 1 Insert the beam into the cart base.

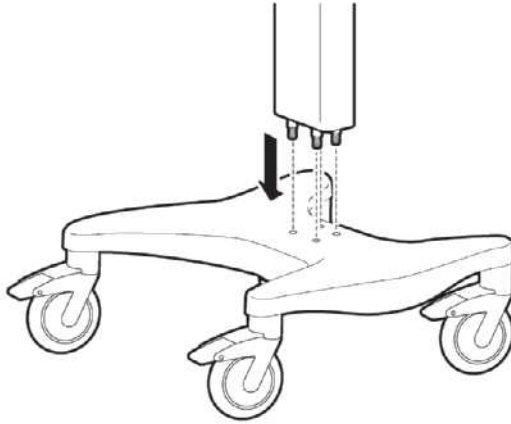

- 2 Hold the beam steadily. Turn the cart onto the side to expose the bottom of the cart.

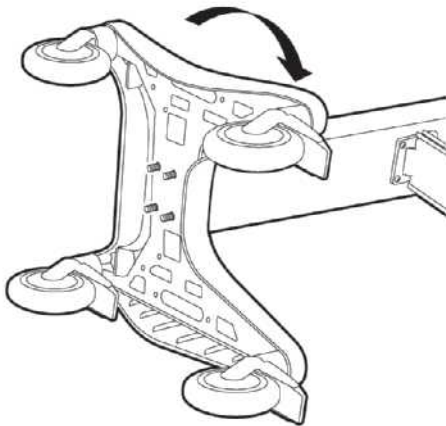

- 3 Place the ground strap onto the screw end.

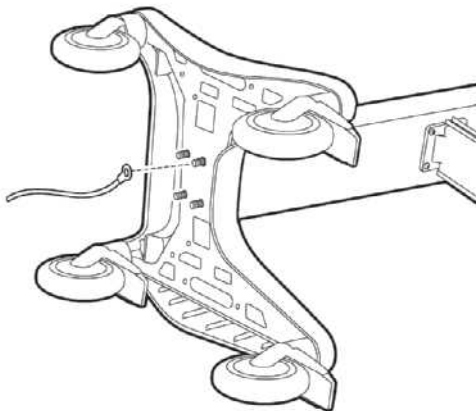

- 4 Attach the bolt screws and tighten using the provided wrench. Ensure that the bolt screws are tightened to 80-100 in lbs.



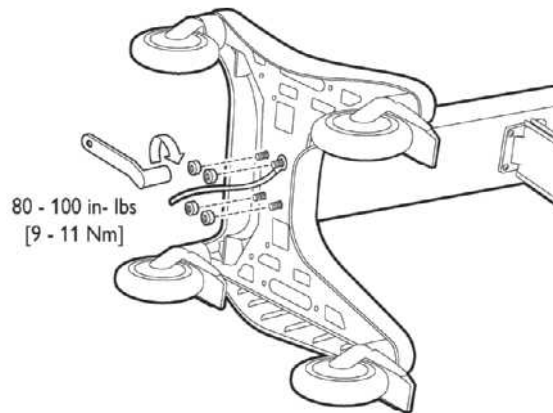

- 5 Turn the cart upright.
- 6 Attach the top shelf to the beam using the provided bolts and wrench. Tighten the bolts to 80-100 in lbs.

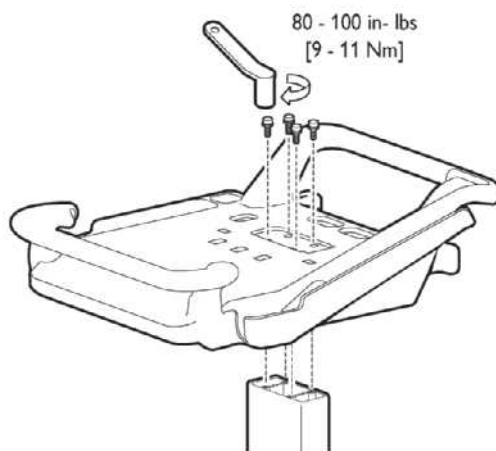

## Attaching the Cardiograph to the Cart

**CAUTION** Follow the procedure below to ensure that the cardiograph is securely fastened to the cart before use.

**To attach the cardiograph to the cart:**

- 1 Align the rear feet of the cardiograph with the rear locking holes on the cart. Align the front feet of the cardiograph with the front screw holes on the cart. Lower the cardiograph on the cart and snap into place.

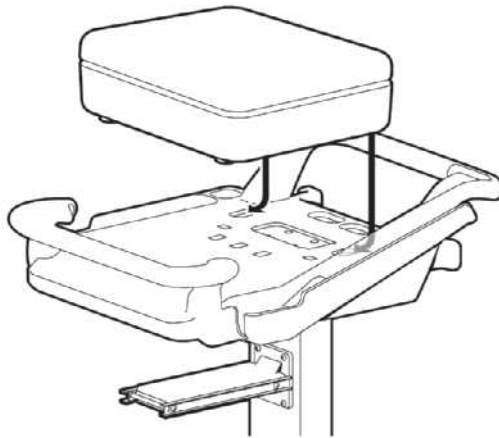

- 2 Insert the front screws through the bottom of the base, and tighten.

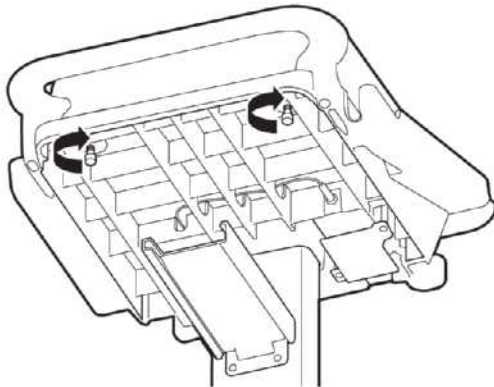

- 3 Slide the drawer onto the cart as shown.

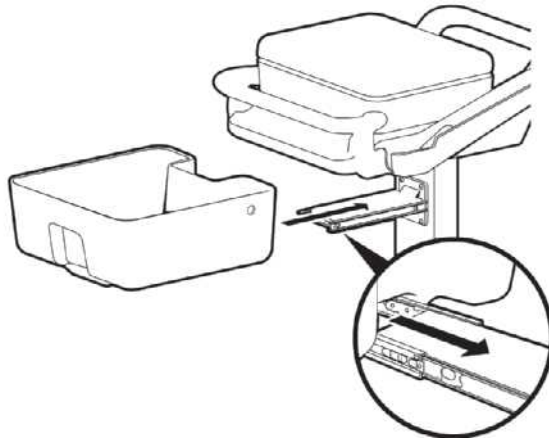

## Attaching Other Cart Accessories and Replacement Parts

There are various cart accessories and replacement parts. See Chapter 6, “Parts and Supplies” for ordering information. Refer to the assembly instructions that come in the kit.

Optional cart accessories include:

- Patient cable arm
- Cart storage bin
- Wire basket

The following cart replacement parts are available:

- Power supply
- Directional locking caster
- Full locking caster
- Swivel caster



---

# Theory of Operation

This chapter provides the following information:

Overview .....	8-2
Hardware Logical View .....	8-2
Main Board .....	8-2
Display .....	8-4
Patient Interface Module (PIM) .....	8-4
Printer Control (FPGA) .....	8-4
Battery (Lithium Ion) .....	8-4
Keyboard and Buttons .....	8-4
Touch Screen .....	8-4
LAN Interface .....	8-4
Magnetic Card Reader (PS/2) .....	8-5
Barcode Reader (PS/2) .....	8-5
Smart Card Reader .....	8-5
USB Memory Stick .....	8-5
Compact Flash Wireless LAN Card .....	8-6
Modem Module .....	8-6
High Level ECG Data Flow and Storage .....	8-6
Internal Main Archive .....	8-8
Internal Remote Archive .....	8-8
External USB Memory Stick Archives .....	8-8
Rendered ECG Report Prints .....	8-8
Fax-Rendered ECG Report Print .....	8-9
Power System Overview .....	8-10
Battery .....	8-10
Voltage Rails .....	8-11
Power Management .....	8-13
Battery Power Indicator .....	8-14
Battery Discharging .....	8-15
Battery Charging .....	8-15
Charge Current .....	8-15
Battery Information .....	8-15

## Overview

At a system level, the PageWriter TC70 cardiograph performs acquisition, analysis, printing, storage, and transfer of ECG waveforms and other patient clinical data.

The PageWriter TC70 cardiograph consists of three major subsystems:

- *Main board*

A main control board built around a powerful embedded processor (Marvell PXA270) with extensive I/O facilities, running Windows CE 5.0. The PageWriter TC70 application software runs on the main board, which supports the display and user-input subsystems.
- *Print controller*

A FPGA-based (Altera Cyclone-II) control circuit, embedded in the main board that provides all the real-time management of the printer.
- *Patient Interface Module (PIM)*

An embedded processor (Marvell PXA270) running Windows CE 5.0, coupled with a signal acquisition board employing Philips proprietary mixed-signal ASIC technology for ECG acquisition. The PIM communicates with the main board through USB.

## Hardware Logical View

Control of the PageWriter TC70 cardiograph is provided by application software running on the main board, interacting with numerous hardware and software subsystems. The following are high-level descriptions of these various subsystems.

### Main Board

The main board contains loader software and the Windows CE kernel image in its internal flash memory 64 MB.

At system boot, a basic interface configuration is performed by the loader and then the Windows CE kernel loads. When Win CE loads, the application launcher runs, verifying system and executable images before loading the main application. All interaction with the user is through the Athena\_APP application. This application software is stored in internal Flash memory.

Figure 8-1 illustrates the devices and interfaces provided by the main control board.

**Figure 8-1 Devices and Interfaces for the Main Control Board**

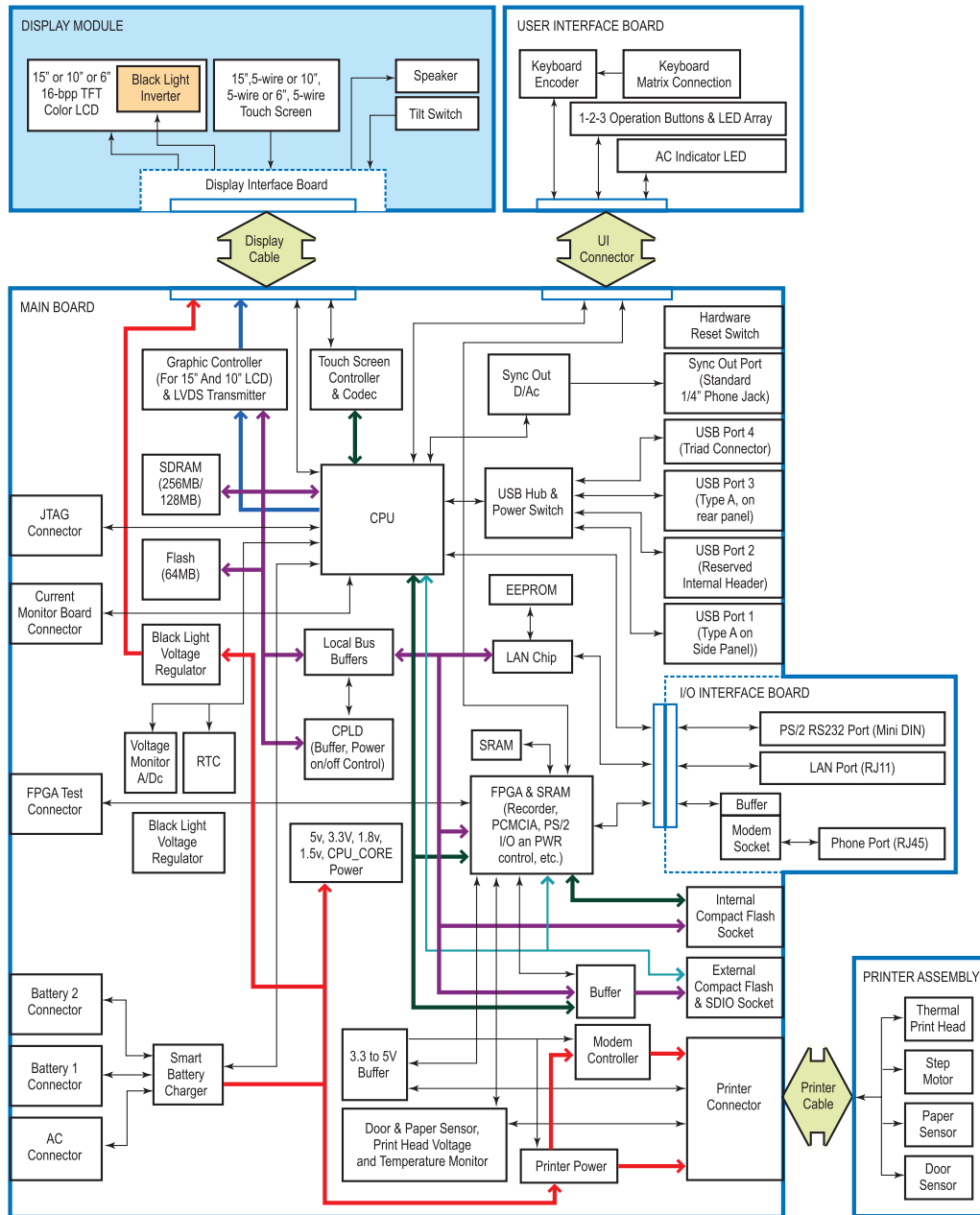

The main control board (together with interface boards and cables) allow the user to access interfaces including Compact Flash wireless LAN, USB connector, the PS/2 connection for a barcode reader device, phone connector for a modem, and an RJ45 connector for LAN.

## Display

The PageWriter TC70 cardiograph display is 1024 x 768 pixels, up to 65536-color TFT LCD with backlight. All display functions are handled by the main control board using the SM501 (Silicon Motion) graphics accelerator chip.

## Patient Interface Module (PIM)

The PIM is a PXA270-based WinCE subsystem that is connected by the USB to the main control board. It provides real-time data acquisition of ECG signals from electrodes connected to the patient.

## Printer Control (FPGA)

All data printing is handled by the main control board. The printer control is an Altera FPGA-based control circuit. It accepts printable data, provides basic bitmap imaging operations, and controls the printer head and motor.

## Battery (Lithium Ion)

The PageWriter TC70 cardiograph uses two battery packs. Each battery is a lithium ion, 11.1-volt, providing 7.2 amp-hours of current when fully charged.

## Keyboard and Buttons

The PageWriter TC70 cardiograph includes a laptop-format, PS/2, sealed, full-key action keyboard. Also included are three function buttons, used to turn the cardiograph on and off, for patient ID input, and ECG capture. These three function buttons are designed to support the 1-2-3 ECG capture operation and have LED backlights to illustrate their current status.

The keyboard function includes a keyboard matrix, a PS/2 encoding chip on an interface board, and is managed through standard Win CE device drivers.

## Touch Screen

The PageWriter TC70 cardiograph includes a 5-wire resistive touch screen in front of the LCD panel. The touch screen provides access to all of the cardiograph features. Users simply touch the buttons on the screen to open the different screens and to perform different functions. The touchscreen is controlled by WM9712 (Wolfson) on the main board to sense the touched position, while application software responds accordingly in different screens.

## LAN Interface

The PageWriter TC70 provides standard LAN capability through a LAN91C111 (SMSC) 10/100M LAN controller. The PageWriter TC70 cardiograph communicates with TraceMasterVue ECG Management System through the LAN interface.



## Magnetic Card Reader (PS/2)

A magnetic card reader is available as an option for the PageWriter TC70. The reader connects to the cardiograph through an external PS/2 connector and provides ISO and standard encoded magnetic strip support. Manual removal and insertion is required.

**NOTE** The PS/2 port is not a plug-and-play port. You must attach the magnetic card reader to the port before powering on the cardiograph.

## Barcode Reader (PS/2)

A barcode reader is available as an option for the PageWriter TC70. The reader connects to the cardiograph through an external PS/2 connector and provides standard barcode scanning capability. It emulates a keyboard, allowing scanned codes to be presented to the PageWriter TC70 cardiograph as if they had been typed on the standard keyboard, powered by a PS/2 connection. The barcode reader can be configured using special barcodes.

**NOTE** The PS/2 port is not a plug-and-play port. You must attach the barcode reader to the port before powering on the cardiograph.

## Smart Card Reader

A Smart Card Reader is available as an option for the PageWriter TC70. The reader connects to the cardiograph through an external USB connector and provides standard Smart Card reading capability. The PageWriter TC70 cardiograph can use the Smart Card Reader to obtain patient information.

## USB Memory Stick

A USB memory stick is available as an option for the PageWriter TC70. The memory stick connects to the cardiograph through the USB connector located on the right side of the cardiograph (with the front of the cardiograph facing you). The USB memory stick can be used to store and transfer ECGs and orders between the cardiograph and a TraceMaster or TraceMasterVue ECG Management System.

---

**CAUTION** Do not insert a USB memory stick into the cardiograph, or remove a USB memory stick from the cardiograph when the cardiograph is acquiring ECG data from a patient.

---

---

**CAUTION** Only use the USB memory stick to transfer data between the cardiograph and a computer. Do not use the USB memory stick with other devices.

---

**NOTE** Some USB memory sticks contain unsupported software, such as SanDisk U3, and are not recognized by the cardiograph. Uninstall any unsupported software from the USB memory stick before using it.

## Compact Flash Wireless LAN Card

A Compact Flash wireless LAN Card is available as an option for the PageWriter TC70. The LAN card connects to the cardiograph through the Wireless LAN card slot and provides standard WLAN capability and is compatible with the 802.11b/g wireless standard. The PageWriter TC70 cardiograph communicates with the TraceMaster or TraceMasterVue ECG Management System through the wireless PCMCIA LAN Card.

## Modem Module

A modem module is available as an option for the PageWriter TC70. The modem is installed on the I/O module and interfaces to the main board through an RS232 connection, providing standard modem capability. The PageWriter TC70 cardiograph faxes ECG data to remote receivers or communicates with a TraceMaster or TraceMasterVue ECG Management System through the modem module.

---

**WARNING** Do not connect the modem card to a phone line when the cardiograph is connected to a patient.

---

## High Level ECG Data Flow and Storage

General ECG data flow begins with acquisition by the Patient Interface Module (PIM) from electrodes placed on a patient. Data is streamed real-time to the main control board, where it is received into the application buffers in RAM. These buffers are used to present the signal data on the real-time screen. When the user initiates an Auto ECG print, the corresponding 10-second segments of the signal data are then copied to the temporary ECG storage memory in RAM.

These 10-second segments are named ECG reports that can be previewed and printed. In the case of Auto mode, the ECG report may be configured to automatically print. An ECG report contains signal data, analysis information, patient demographics, and acquisition information, along with operator and device information. See the *XML Utility Suite Instructions for Use* available on the Philips InCenter site ([incenter.medical.philips.com](http://incenter.medical.philips.com)) for a complete description of the contents of the ECG data record. For information on using the InCenter site, see “Using the Philips InCenter Site” on page 1-4.

If the **Save** button on the cardiograph is set to **Auto**, the ECG report is saved in XML format to the internal main archive. This archive is non-volatile and resides on the internal CompactFlash (CF) card. An index files with a CDB extension is also maintained in this archive.

From the internal main archive, the ECG XML data format files can be copied, deleted, previewed, printed, and transferred to other devices. The internal main archive cannot receive ECG XML files from external devices. Retrieved ECG file storage is limited to the internal remote archive.

**NOTE** PageWriter TC70-generated ECG XML files comply with the Philips Medical Systems ECG XML Schema version. They incorporate an embedded CRC32 value, which is used to ensure the data integrity of the file.

Figure 8-2 ECG Flow and Storage

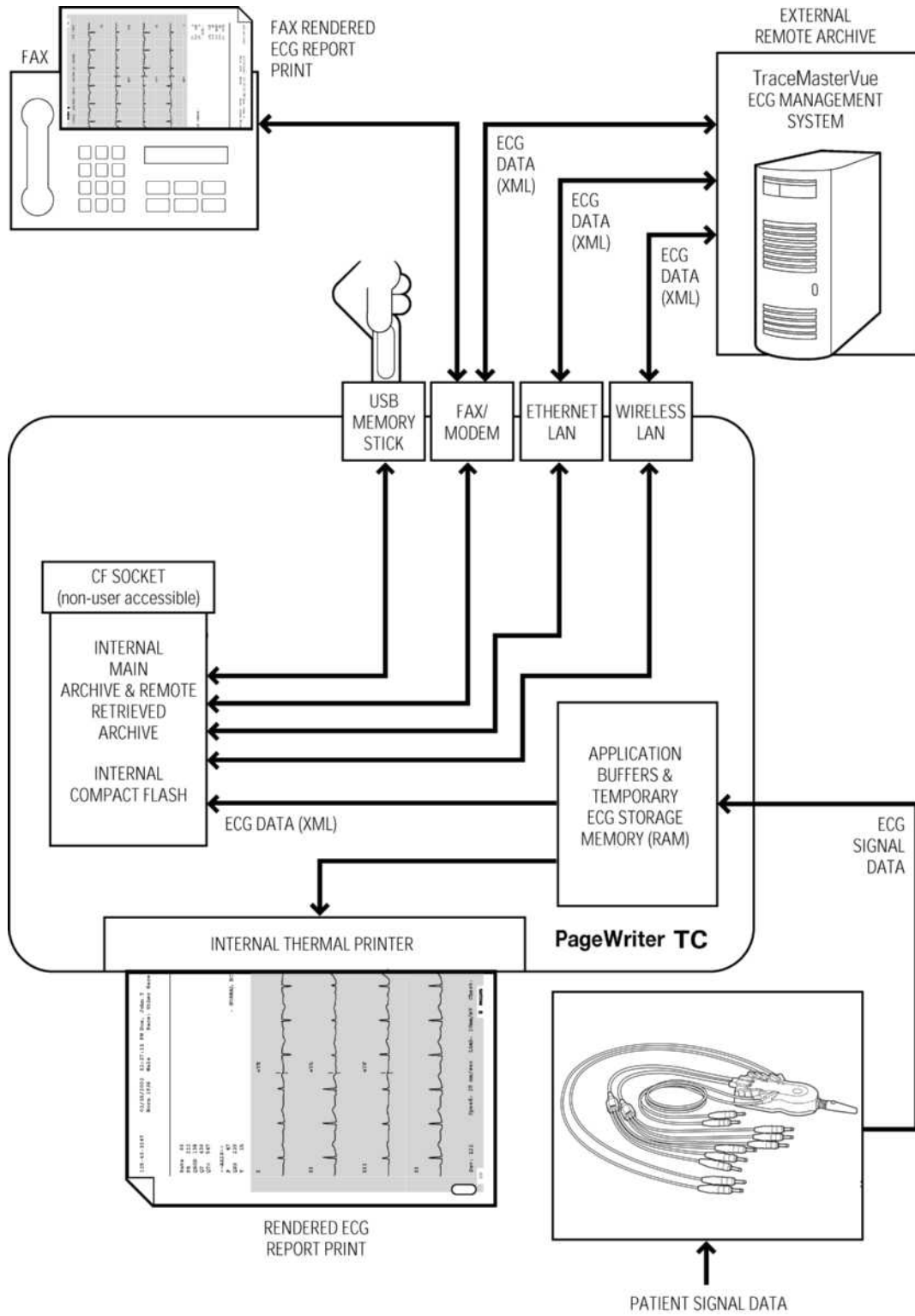

## Internal Main Archive

The internal main archive resides on the internal CompactFlash (CF) card, and is used as the primary ECG data repository. This archive is referred to as the **Main Archive** in the software application. ECG XML files and related index file is stored here in the `PhilipsArchiveInternal` directory. All stored ECG files transition through this archive prior to transfer or copying to other devices, such as the USB memory stick.

Currently, the internal main archive is limited to storing 200 ECGs.

## Internal Remote Archive

The internal remote archive resides on the internal CompactFlash (CF) card much like the internal main archive. All XML files retrieved from remote sites, such as the TraceMasterVue ECG Management System, reside in this archive until deleted. ECG XML files and related index files are stored in the `PhilipsArchiveRemote` directory.

Currently, the internal remote archive is limited to a maximum of 100 ECGs.

## External USB Memory Stick Archives

The external USB memory stick archives reside on a compatible memory stick connected to the USB port. Files can then be transferred to a connected memory stick using the **Archive** feature of the application software, and are stored in XML format. A CDB file is created and maintained on each compatible USB memory stick when ECG files are transferred to the USB memory stick. Currently, a USB memory stick archive is limited to storing 200 ECGs.

**NOTE** The PageWriter TC70 cardiograph only supports the USB memory stick that is shipped with the cardiograph, or that is available for purchase as an optional accessory from Philips Medical Systems. Philips does not guarantee that other USB memory sticks are compatible with the PageWriter TC70 cardiograph.

When you add or delete compatible ECG XML files from a memory stick (not using the cardiograph), it is recommended that you delete all CDB files prior to reconnecting the memory stick to the cardiograph. In the absence of a CDB file, the cardiograph automatically regenerates the index based on the XML files on the memory stick.

## Rendered ECG Report Prints

A rendered ECG report print is a hard copy representation of the ECG data. This includes a high-resolution print of the signal data, and may include configured patient demographics, acquisition information, and other non-signal data elements.

The PageWriter TC70 allows the user to customize the fields on an ECG report print. The report print may consist of one or more continuous pages on perforated thermal media from the printer.

**Figure 8-3 Rendered ECG Report Print Sample**

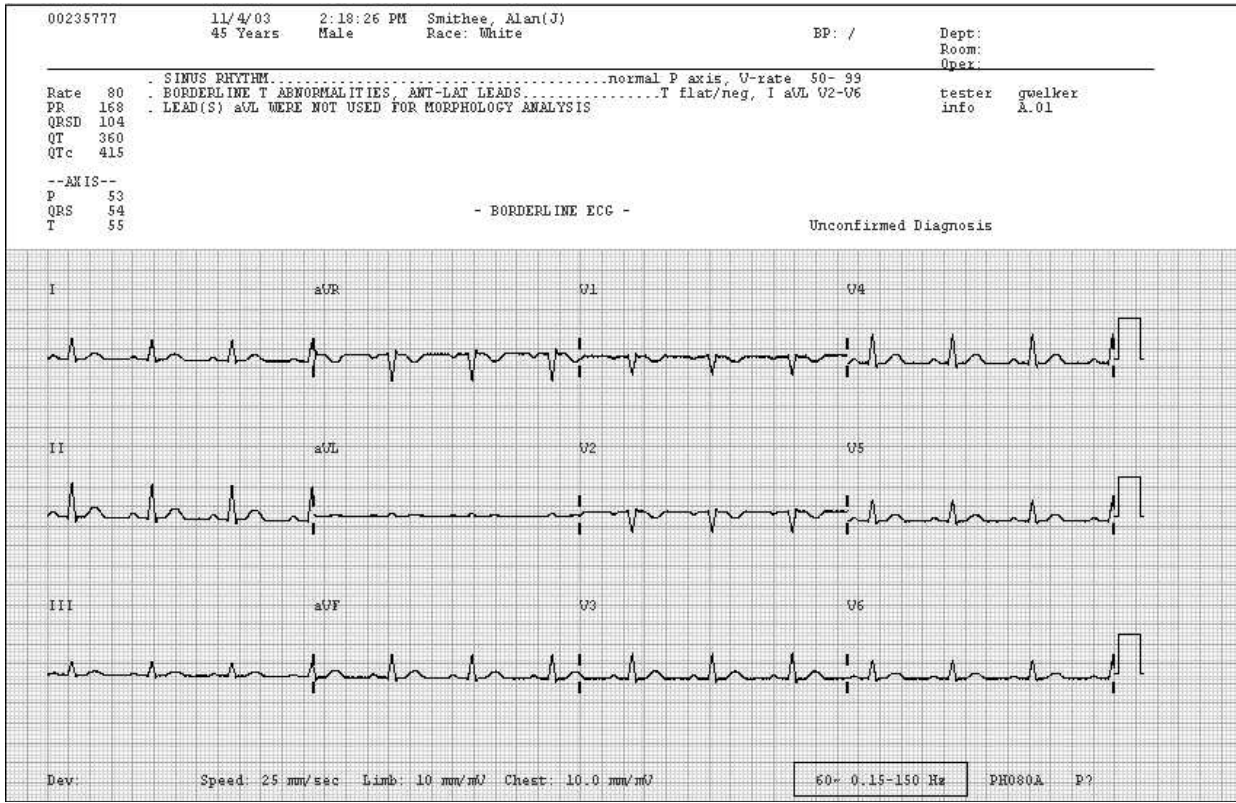

### Fax-Rendered ECG Report Print

A fax-rendered ECG report print is equivalent to the rendered ECG report print, as described in the previous section, except it has been adjusted to comply with fax transmission and resolution device requirements. When the user starts a fax transfer, the ECG report is rendered and transmitted to a remote receiving fax machine that has been pre-configured on the cardiograph, using the optional fax and modem. The fax-rendered ECG report print may be stored on the received system end as an electronic file, and not actually used to produce a printed copy.

**NOTE** No guarantee is made as to the suitability of the faxed 12-lead ECG for any particular purpose, due to the variability inherent in fax technology.

---

**WARNING** Do not connect the modem card to a phone line when the cardiograph is connected to a patient.

---

## Power System Overview

The PageWriter TC70 cardiograph power system consists of:

- One 80-watt AC/DC medical grade power module
- Two 11.1 volt, 7.2amp-hour lithium ion rechargeable batteries
- Battery charging circuitry, various voltage regulators, and logic circuitry on the main board

The PageWriter TC70 cardiograph is designed to run on AC power or battery. The main board contains a battery charging chip that controls battery charging. The main board has an A/D converter that monitors the voltage of the power supply, and a smart battery controller (part of the charging chip) that monitors the battery charging status.

The major power draws within the PageWriter TC70 cardiograph are the LCD display backlights, which can draw up to 19 watts, and the thermal printer, which can draw approximately 35 watts. Provisions have been incorporated into the PageWriter TC70 cardiograph that allow the user to adjust the display brightness. To extend battery life, set the display brightness to the low or medium setting. Also, activate the power save mode (entering standby) to further extend battery life. The printer control circuitry is current-limited for normal printing. However, if print demand is too high, the current limiter will not print the output, resulting in a faded page. For more information on configuring power saving options on the cardiograph, see Chapter 2 “Configuration” of the *PageWriter TC70 Cardiograph Instructions for Use*, available for download from the Philips InCenter site ([incenter.medical.philips.com](http://incenter.medical.philips.com)).

### Battery

The two 11.1V rechargeable lithium ion batteries provides power to the PageWriter TC70 cardiograph and can support full cardiograph functionality without AC when properly charged. Built-in protection circuitry in each pack prevents damage to the battery by overcharging, over discharging, over current, and over temperature.



### **Load\_PWR**

The voltage is supplied by  $V_{in}$  and the battery. Its range is between 9.0V to 14.43V. This voltage is monitored.

### **+3.3V**

Output from regulator U1401 (LTC1628). The input to this regulator is from Loads\_PWR and can supply 3.3V at up to 4.0A of current. This voltage is monitored.

### **VCC\_RTC**

Output from regulator U1403 (LT3470) for the real timer and power sequence circuit. The voltage level is 3.3V, and can provide up to 200mA of current. This voltage is not monitored.

### **VCC\_Core (+1.5V)**

Output from regulator U1202 (LTC3445) which is 1.5V core power for the embedded processor. The input to this regulator is from the 3.3V supply and can supply up to 600mA of current. This voltage is monitored.

### **VCC\_SRAM (+1.1V)**

Output from regulator U1202 (LTC3445), which is 1.1V SRAM power for the embedded processor. The input to this regulator is from the +3.3V supply, and can supply up to 50mA of current. This voltage is not monitored.

### **VCC\_PLL (+1.3V)**

Output from regulator U1202 (LTC3445), which is 1.3V PLL power for the embedded processor. The input to this regulator is from the +3.3V supply, and can supply up to 50mA of current. This voltage is not monitored.

### **VCC\_1P8 (+1.8V)**

Output from regulator U1201 (LTC3404), which is 1.8V power for the flash memory core. The input to this regulator is from the +3.3V supply, and can supply up to 600mA of current. This voltage is monitored.

### **VCC\_1P5 (+1.5V)**

Output from regulator U1203 (LTC3406), which is 1.5V core power for the FPGA. The input to this regulator is from the +3.3V supply, and can supply up to 600mA of current. This voltage is monitored.

### **VCC\_INT\_PLD (+1.8V)**

Output from regulator U1402 (LT1761), which is 1.8V power for the CPLD core. The input to this regulator is from the +3.3V supply, and can supply up to 100mA of current. This voltage is not monitored.



**+5V**

Output from regulator U1401 (LTC1628) which supplies all the 5.V power to the system. Input is from Load\_PWR, and output is 4.87 to 5.24 VDC with a maximum current of 3A. This voltage is monitored.

**USB4\_VCC**

Output from switch U702 (LM3525) which supplies the PIM power. Input is from +5V, and output is 5V with maximum current of 1.0A. This voltage is monitored.

**VM**

Output from regulator U1501 (LM2588), which supplies +26V power to the print head and motor. This voltage is not monitored.

**VCC\_PRNHD**

Output from switch Q1503, which supplies +26V power to the print head. It is controlled by FPGA on the main board. VCC\_PRNHD provides power only when a print session starts. Otherwise, VCC\_PRNHD does not provide power. This voltage is monitored byFPGA.

**VCC\_MOTOR**

Output from switch Q1501, which supplies +26V power to the print motor. It is controlled by FPGA on the main board. VCC\_MOTOR provides power only when a print session starts. Otherwise, VCC\_MOTOR does not provide power. This voltage is not monitored.

**VCC\_BKLGT**

Output from regulator U1504 (LTC3780), which supplies display backlight. Input is from Load\_PWR and output is 12V with a maxim current of 3.5A.

**Power Management****Power Modes Control**

The system host processor controls transition between power modes, including:

- Entering standby mode if no activity is detected for a preset period of time (upon configuration).
- Powering off the unit if no activity is detected for a preset period of time (upon configuration).
- Entering standby mode or off mode, when battery remaining capacity is below preset level and no AC power is applied.

## Battery Charging Logic

Battery charging is controlled by the charger chip. The charger chip can:

- Charge the battery when the system is in off mode, standby mode and run mode.
- Alert the user when charging is recommended for the battery, when the system is powered by battery only.

## Battery Power Indicator

The battery power indicator appears on the Status Bar and is always visible. The indicator displays the current battery power level. The cardiograph can operate on AC power while the batteries are charging.

**Figure 8-5 Battery Power Indicator on the Status Bar**





**A** Battery level indicator

You can touch the Battery Power Indicator on the Status Bar to ensure that the batteries are fully charged. The Battery Status Information window appears. This window provides detailed information on the status of the cardiograph batteries.



**NOTE** The battery indicator may not always accurately reflect the true charge state of the battery due to the age of the battery, or due to failure to perform specified battery maintenance.

Table 8-1 describes the battery level indicator.

**Table 8-1 Battery Level Indicator Information (icon on Status Bar)**

Battery Level	Icon on Status Indicator
Fully Charged Battery	
75% power capacity	
50% power capacity	

**Table 8-1 Battery Level Indicator Information (icon on Status Bar)** *(continued)*

Battery Level	Icon on Status Indicator
Low Battery Power: <ul style="list-style-type: none"> <li>■ red battery icon appears when power level is between 20-30%</li> <li>■ cardiograph <i>beeps</i> and an error message appears until the unit is plugged into AC power</li> <li>■ touch the icon to see how many minutes are left of operating battery power</li> </ul>	
No or Dead Battery	

## Battery Discharging

If no AC power is applied to the system, when the batteries are discharged to the 15% level, the PageWriter TC70 cardiograph automatically enters standby mode and alerts the user to apply AC power. When the batteries are discharged to a 12% level, the PageWriter TC70 cardiograph automatically shuts down.

**NOTE** The battery will continue to discharge when the cardiograph is not in use, or if the battery is stored outside of the cardiograph.

## Battery Charging

When the AC power cord is plugged in, the battery begins to charge. Check the charging status through the Service Utilities. See “Running the Service Utilities” on page 3-35 for more information.

## Charge Current

When AC power is applied to the cardiograph, the batteries are charged at maximum 3A total current. Check the charging current through the Service Utilities. See “Running the Service Utilities” on page 3-35 for more information.

## Battery Information

Battery information is sent from the battery charger, U1301. This information is then sent to the host processor via SMBUS, and can be viewed from the Service Utilities screen. See “Running the Service Utilities” on page 3-35 for more information.



# Specifications

This chapter provides the following information:

Technical Specifications	A-2
ECG Acquisition	A-2
Keyboard	A-2
Touchscreen Display	A-2
Display Accuracy	A-2
Patient Interface Module	A-2
Patient Interface Module Signal Acquisition	A-2
Signal Processing/Acquisition	A-2
Auto Frequency Response	A-3
Rhythm Frequency Response	A-3
Minimum Amplitude or Value of Patient Physiological Signal	A-3
Filters	A-3
Printer	A-3
Report Formats	A-3
Battery Operation	A-4
Network Connection	A-5
FAX Capability (optional)	A-5
Modem (optional for USA and Canada)	A-5
Barcode Reader (optional)	A-5
Magnetic Card Reader (optional)	A-5
Smart Card Reader (optional)	A-5
ECG Storage	A-5
Orders	A-6
ECG File Formats	A-6
Power and Environment	A-6
Environmental Operating Conditions	A-6
Environmental Storage Conditions	A-7
Cardiograph Dimensions	A-7
Cardiograph Weight	A-7
Cardiograph Shipping Container Weight	A-7
Safety and Performance	A-7
Classification (IEC 60601-1)	A-8
Electromagnetic Compatibility (EMC)	A-8
Reducing Electromagnetic Interference	A-9
Wireless LAN Card Specifications	A-14

# Technical Specifications

## ECG Acquisition

- Auto ECG (12 leads standard; up to 16 leads *optional*)
- Rhythm ECG (12 leads standard; up to 16 leads *optional*)
- Disclose (1 to 12 leads standard; 1 to 16 leads *optional*)

## Keyboard

- Full alphanumeric capability QWERTY keyboard

## Touchscreen Display

- 1024 x 768 graphics resolution with 18-bit pixel color depth
- 30.4 cm x 22.8 cm (11.96 x 8.97 in) color liquid crystal touch screen display with backlight

## Display Accuracy

- The accuracy of the ECG signals are within +/- 5% (or +/- 40 uV whichever is greater), over a range of 0 to 5 mV, in the presence of differential and common mode DC offset voltages of +/- 300 mV. The cardiograph performance is tested to comply with the accuracy requirements over the dynamic ranges and frequency ranges specified in the IEC 60601-2-51 and AAMI EC-11 standards.
- For additional details regarding accuracy and precision, refer to the *Physician's Guide* and the Manufacturer's Disclosure Statement.

## Patient Interface Module

- Remote, microprocessor-controlled module
- ECG button with signal quality indicator allows user to take ECGs from the bedside

## Patient Interface Module Signal Acquisition

- 8,000 samples per second per electrode/lead for standard 12 or up to 16 leads

## Signal Processing/Acquisition

### Sampling Rate

- 500 samples per second per electrode/lead
- 12 bit A/D conversion provides down sampled 5µV resolution, 500 samples per second measurement with no channel to channel skew

## Auto Frequency Response

0.05-150 Hz, 0.15-150 Hz, 0.5-150 Hz  
0.05-100 Hz, 0.15-100 Hz, 0.5-100 Hz  
0.05-40 Hz, 0.15-40, 0.5-40 Hz

## Rhythm Frequency Response

0.05-150 Hz, 0.15-150 Hz, 0.05-150 Hz  
0.15-100 Hz, 0.05-40 Hz, 0.15-40 Hz

## Minimum Amplitude or Value of Patient Physiological Signal

---

**CAUTION** The QRS wave must be a minimum of 100 $\mu$ V peak to peak or greater for the lead's complex to be measured. The operation of the cardiograph below this value may cause incorrect ECG analysis.

---

## Filters

- AC noise
- Baseline Wander
- Artifact

## Printer

### Printer Resolution

- High-resolution, digital-array printer using thermal-sensitive paper
- 200 dpi (voltage axis) by 500 dpi (time axis)

## Report Formats

### Exam Profiles

- Up to 12 configured Exam Profiles can be specified
- Exam Profiles define all ECG report settings; these settings can be manually overridden if necessary

### 12 Lead Report Formats

- 3x4 (1R, 3R)
- 3x4, ST
- 3x4, 1R ST

- 6x2
- Panoramic 12 (Cabrera sequence only)
- 12x1
- Extended Measurements

### **16 Lead Report Formats**

- 3x5 (1R, 3R)
- 4x4 (1R)
- Extended Measurements

### **Rhythm Report Formats**

- Rhythm (up to 12, or up to optional 16 selected leads)

## **Battery Operation**

- The PageWriter TC70 cardiograph is designed to be operated with two batteries installed, and the battery operational time listed in this section is based upon cardiograph operation with both batteries installed. Operation with a single battery is not supported or recommended as it will shorten operational time and decrease overall battery life.
- SMBus compliant batteries

### **Voltage**

- 9.0 to 12.6 VDC

### **Current**

- 4.0 A max per battery (continuous)

### **Power**

- 35 to 44 W max per battery (continuous)
- 54 W max per battery (2 second peaks)

### **Capacity**

- 2 hours and 25 minutes (continuous Rhythm printing with the Display Brightness setting at the maximum setting)

### **Status Display**

- Full Charge Capacity (mAHR)
- Remaining Capacity (%)



- Temperature (deg C)
- Discharge Current (mA)
- Charge Current (mA)
- Low battery audio and visual alerts

### **Recharge**

- Less than five hours if cardiograph is in Standby (not in active use) to at least 95% capacity
- Less than eight hours if the cardiograph is in active use to at least 95% capacity

### **Network Connection**

- 10/100 Base-T IEEE 802.3 Ethernet via RJ45 connector (standard)
- Optional software required for wireless LAN connection. Wireless LAN connection is 802.11g compatible.
- Supports up to 8 individual TraceMasterVue Remote Site connections

### **FAX Capability (optional)**

- Group 3, Class 1 or 2 fax

### **Modem (optional for USA and Canada)**

- V.90, K56flex, enhanced V.34, V.32bis, V.32, V.22bis and below

### **Barcode Reader (optional)**

- Reads Code 39 (standard and full ASCII)

### **Magnetic Card Reader (optional)**

- Reads cards adhering to ISO 7810, 7811-1, -2, -3, -4, -5, and JIS X 6301 and X6302

### **Smart Card Reader (optional)**

- Reads cards adhering to ISO/IEC 7816, identification cards through integrated circuit cards
- Supports EMV (Europay, Mastercard, Visa) Common Standard for Smart Card based payment

### **ECG Storage**

- XML File Format in version 1.03, 1.04, 1.04.01, and 1.04.02

- Up to 200 ECGs to internal flash memory
- Up to 200 ECGs per USB Memory Stick (optional)

## Orders

- Receives orders from the OrderVue Order Management System that resides on a TraceMasterVue ECG Management System
- Up to 200 pending orders can be stored on the cardiograph

## ECG File Formats

- XML and XML SVG

## Power and Environment

### AC Adapter

Philips part number

- 17.78 cm (7 inches) long, 8.25 cm (3.25 inches) wide x 4.45 cm (1.75 inches) height
- Weight: .73 kg (1.62 pounds)
- RoHS compliant
- Input voltage: 100 to 240 Volts
- Input voltage frequency: 50 to 60 Hz
- Input current: 1.4 - 0.7 A
- Power: 80 W Max
- Output Voltage: 15 Volts dc 5.33A
- Output Voltage Regulation: 5% Max
- Output Current: 5.33 A Max
- Output Ripple Voltage: 250 mVpp Max

### Line Power

- 100-240 VAC
- 50/60 Hz
- 100 VA Max

## Environmental Operating Conditions

- 10° to 40 °C (50° to 104°F)

- 15% to 80% relative humidity (non-condensing)
- Up to 4,572 m (15,000 ft.) altitude, 572 hPA

### **Environmental Storage Conditions**

- -20° to 50 °C (-4° to 122°F)
- 15% to 80% relative humidity (non-condensing)
- Up to 4,572 m (15,000 ft.) altitude, 572 hPA

### **Cardiograph Dimensions**

- 330 mm wide x 405 mm deep x 135 mm height (12.99 inches wide x 15.94 inches deep x 5.31 inches height) with top cover in down position

### **Cardiograph Weight**

- 11 kg (28 lb) including accessories

### **Cardiograph Shipping Container Weight**

- 16.6 kg (24.25 lb)

## **Safety and Performance**

Meets the following requirements for safety and performance:

- IEC 60601-1: 1988 +A1:1991 +A2:1995 Medical electrical equipment – Part 1: General requirements for Safety (Includes national differences for standards AS/NZS 3200.1.0: 1998, CAN/CSA-C22.2 No. 60601-1-M90 +B: 90 +S1: 94, EN 60601-1: 1990 +A1: 1993 +A11: 1993 +A12: 1993 +A13: 1996, JIS T 0601-1: 1999, UL 60601-1: 2003)
- IEC 60601-2-25: 1993 +A1:1999 Particular requirements for the safety of electrocardiographs (Includes national differences for standards AS/NZS 3200.2.25: 1993, CAN/CSA-C22.2 No. 60601-2-25: 1994 +A1: 2002, EN 60601-2-25: 1995 + A1: 1999)
- IEC 60601-2-51: 2003 Particular requirements for safety, including essential performance, of recording and analyzing single channel and multi-channel electrocardiographs (Includes national differences for standards CAN/CSA-C22.2 No. 60601-2-51: 2004, EN 60601-2-51: 2003)
- IEC/EN 60601-1-2 2001: 2nd ed Electromagnetic compatibility- Requirements and tests
- AAMI EC11: 1991 (R: 2001) Diagnostic Electrocardiographic Devices

## Classification (IEC 60601-1)

### Class II (Internally Powered)

Symbol	Meaning
	ECG physio isolation is type CF, defibrillator proof. Suitable for all patient applications including direct cardiac application. System is in continuous operation.
<b>IPX 0</b>	Cardiograph has ordinary protection against the entry of liquids.
<b>IPX4</b>	The PIM (patient interface module) is protected against splashing water. Water splashed against the PIM from any direction shall have no harmful effect.

- Cardiograph is not suitable for use in the presence of flammable anesthetic mixture with air, oxygen, or nitrous oxide.
- System is continuous operation.

---

**WARNING** When using additional peripheral equipment powered from an electrical source other than the cardiograph, the combination is considered to be a medical system. It is the responsibility of the operator to comply with IEC 60601-1-1 and test the medical system according to the requirements. For additional information contact Philips Medical Systems.

---

## Electromagnetic Compatibility (EMC)

Electronic devices can either generate or receive electromagnetic interference. The PageWriter TC70 has been evaluated for electromagnetic compatibility (EMC) with the appropriate accessories according to Medical Collateral standard IEC 60601-1-2:2001 (with exceptions noted in proceeding tables). This IEC standard has been adopted in the European Union as the European Norm, EN 60601-1-2:2001.

---

**WARNING** Radio frequency (RF) interference from nearby transmitting devices may degrade performance of the electronic equipment. Electromagnetic compatibility with surrounding devices should be assessed prior to using the equipment.

---



---

**WARNING** Fixed, portable, and mobile radio frequency communications equipment can also affect the performance of electrical equipment. See your Service Provider for assistance with the minimum recommended separation distance between RF communications equipment and the PageWriter TC70 cardiograph.

---

---

**WARNING** The use of accessories and cables other than those specified in the Philips PageWriter TC70 system service and user documentation can result in increased emissions or decreased immunity of the system.

---



---

**WARNING** The PageWriter TC70 cardiograph should not be used next to or stacked on top of other equipment. If you must stack the product, you must check that normal operation is possible in the necessary configuration before the product is used.

---

## Reducing Electromagnetic Interference

The PageWriter TC70 cardiograph and accessories may become sensitive to interference from other RF energy sources including power lines. RF energy sources include other medical devices, wireless devices, information technology equipment, and radio/television transmission. Should interference be encountered, as demonstrated by artifact on the ECG trace, unintended change on operating state, or unit lockup, attempt to locate the source by assessing:

- if the interference is intermittent or constant?
- does the interference occur only in certain locations?
- does the interference occur only when in close proximity to certain medical devices?
- does the ECG signal quality change dramatically when the AC power cord is unplugged?

Once the source of the interference is located, attempt to attenuate the EMC coupling path by distancing the cardiograph from the source of the interference as much as possible. If further assistance is needed, contact the Philips Response Center nearest you.

**Table A-1 Guidance and Manufacturer's Declaration: Electromagnetic Emissions**

The PageWriter TC70 cardiograph is intended for use in the electromagnetic environment specified in the table below. The customer or the user of the PageWriter TC70 cardiograph should assure that it is used in such an environment.

Emissions Test	Compliance	Electromagnetic Environment: guidance
RF Emissions CISPR 11	Group 1	The PageWriter TC70 cardiograph uses RF energy only for its internal function. Therefore, its RF emissions are very low and are not likely to cause any interference in nearby electronic equipment.

**Table A-1 Guidance and Manufacturer's Declaration: Electromagnetic Emissions**

The PageWriter TC70 cardiograph is intended for use in the electromagnetic environment specified in the table below. The customer or the user of the PageWriter TC70 cardiograph should assure that it is used in such an environment.

<b>Emissions Test</b>	<b>Compliance</b>	<b>Electromagnetic Environment: guidance</b>
RF Emissions CISPR 11	Class A	The PageWriter TC70 cardiograph is suitable for use in all establishments other than domestic and those directly connected to the public low-voltage power supply network that supplies buildings used for domestic purposes.
Harmonic Emissions IEC 61000-3-2	Class A	
Voltage fluctuations/ flicker emissions IEC 61000-3-3	Complies	

**Table A-2 Guidance and Manufacturer's Declaration: Electromagnetic Immunity**

The PageWriter TC70 cardiograph is intended for use in the electromagnetic environment specified below. The customer or the user of the PageWriter TC70 cardiograph should assure that it is used in such an environment.

<b>Immunity Test</b>	<b>IEC 60601 Test Level</b>	<b>Compliance Level</b>	<b>Electromagnetic Environment: guidance</b>
Electrostatic Discharge (ESD) IEC 61000-4-2	+/- 6 kV contact +/- 8 kV air	+/- 6 kV contact +/- 8 kV air	Floors should be constructed of wood, concrete, or ceramic tile. If floors are covered with synthetic material, the relative humidity should be at least 30%.
Electrical Fast transient/burst IEC 61000-4-4	+/- 2 kV for power supply lines +/- 1 kV for input/output lines	+/- 2 kV for power supply lines +/- 1 kV for input/output lines	Mains power quality should be that of a typical commercial or hospital environment.
Surge IEC 61000-4-5	+/- 1 kV differential mode +/- 2 kV common mode	+/- 1 kV differential mode +/- 2 kV common mode	Mains power quality should be that of a typical commercial or hospital environment.

**Table A-2 Guidance and Manufacturer's Declaration: Electromagnetic Immunity** (continued)

The PageWriter TC70 cardiograph is intended for use in the electromagnetic environment specified below. The customer or the user of the PageWriter TC70 cardiograph should assure that it is used in such an environment.

Immunity Test	IEC 60601 Test Level	Compliance Level	Electromagnetic Environment: guidance
Voltage dips, short interruptions and voltage variations on power supply input lines IEC 61000-4-11	<5% $U_T$ (>95% dip in $U_T$ ) for 0.5 cycle  40% $U_T$ (60% dip in $U_T$ ) for 5 cycles  70% $U_T$ (>30% dip in $U_T$ ) for 25 cycles  <5% $U_T$ (>95% dip in $U_T$ ) for 5 seconds	<5% $U_T$ (>95% dip in $U_T$ ) for 0.5 cycle  40% $U_T$ (60% dip in $U_T$ ) for 5 cycles  70% $U_T$ (>30% dip in $U_T$ ) for 25 cycles  <5% $U_T$ (>95% dip in $U_T$ ) for 5 seconds	Mains power quality should be that of a typical commercial or hospital environment. If the user of the PageWriter TC70 cardiograph required continued operation during power mains interruptions, it is recommended that the PageWriter TC70 be powered from an uninterruptable power supply or a battery.
Power frequency (50./60 Hz) magnetic field	3 A/m	Complies	Power frequency magnetic fields should be at levels characteristic of a typical location in a typical commercial or hospital environment.

Note:  $U_T$  is the a.c. mains voltage prior to application of the test level.

**Table A-2 Guidance and Manufacturer's Declaration: Electromagnetic Immunity** (continued)

The PageWriter TC70 cardiograph is intended for use in the electromagnetic environment specified below. The customer or the user of the PageWriter TC70 cardiograph should assure that it is used in such an environment.

Immunity Test	IEC 60601 Test Level	Compliance Level	Electromagnetic Environment: guidance
Conducted RF IEC 61000-4-6	3 Vrms 150 kHz to 80 MHz	3 Vrms	Portable and mobile RF communications equipment should be used no closer to any part of the PageWriter TC70, including cables, than the recommended separation distance calculated from the equation applicable to the frequency of the transmitter.  Recommended separation distance  $d = 1.2 \sqrt{P}$
Radiated RF IEC 61000-4-3	3 V/m 80 MHz to 2,5 GHz	3 V/m	$d = 1.2 \sqrt{P}$
			$d = 2.3 \sqrt{P}$  Where $P$ is the maximum output power rating of the transmitter in watts (W) according to the transmitter manufacturer and $d$ is the recommended separation distance in meters (m).  Field strengths from fixed RF transmitters, as determined by an electromagnetic site survey <sup>a</sup> , should be less than the compliance level in each frequency range <sup>b</sup> .  Interference may occur in the vicinity of equipment marked with the following symbol:  

Note 1: At 80 MHz and 800 MHz, the higher frequency range applies.

Note 2: These guidelines may not apply in all situations. Electromagnetic propagation is affected by absorption and reflection from surfaces, objects, and people.



- a. Field strengths from fixed transmitters, such as base stations for radio (cellular/cordless) telephones and land mobile radios, amateur radio, AM and FM radio broadcast and TV broadcast cannot be predicted theoretically with accuracy. To assess the electromagnetic environment due to fixed RF transmitters, an electromagnetic site survey should be considered. If the measured field strength in the location in which the PageWriter TC70 is used exceeds the applicable RF compliance level above, the PageWriter TC70 should be observed to verify normal operation. If abnormal performance is observed, additional measures may be necessary, such as re-orienting or relocating the PageWriter TC70.
- b. Over the frequency range 150 kHz to 80 MHz, field strengths should be less than 3 V/m.

**Table A-3 Recommended Separation Distances Between Portable and Mobile RF Communications Equipment and the PageWriter TC70 Cardiograph: for equipment and systems that are not life-supporting**

The PageWriter TC70 cardiograph is intended for use in the electromagnetic environment in which radiated RF disturbances are controlled. The customer or the user of the PageWriter TC70 cardiograph can help to prevent electromagnetic interference by maintaining a minimum distance between portable and mobile RF communications equipment (transmitters) and the PageWriter TC70 cardiograph as recommended below, according to the maximum output power of the communications equipment.

Rated Maximum Output Power of Transmitter (W)	Separation Distance According to Frequency of Transmitter (m)	
	150 KHz to 800 KHz	800 MHz to 2.5 GHz
0.01	$d = 1.2 \sqrt{P}$	$d = 2.3 \sqrt{P}$
	0.1 m	0.2 m
0.1	0.4 m	0.7 m
1	1.2 m	2.3 m
10	4.0 m	7.0 m
100	12.0 m	23.0 m

For transmitters rated at a maximum output power not listed above, the recommended separation distance  $d$  in meters (m) can be estimated using the equation applicable to the frequency of the transmitter, where  $P$  is the maximum output power rating of the transmitter in watts (W) according to the transmitter manufacturer.

Note 1: At 80 MHz and 800 MHz, the separation distance for the higher frequency range applies.

Note 2: These guidelines may not apply in all situations. Electromagnetic propagation is affected by the absorption and reflection from structures, objects, and people.

## Wireless LAN Card Specifications

The specifications in the following sections are applicable to the Summit SDC-CF20G wireless adapter that is offered as an option for the PageWriter TC70 cardiograph.

### Length

- 72.8 mm (2.87 inches)

### Width

- 43 mm (1.69 inches)

### Thickness

- Card body: 3.3 mm (0.13 inches)
- Antenna: 7.3 mm (0.29 inches)

### Weight

- 21 grams (0.7 ounces)

### System Interface

- 16-bit Compact Flash Type I with 50-pin connector

### Antenna

- 0 dBi gain omnidirectional with diversity

### Chipset

- Broadcom BCM4318E

### Input Power Requirements

- 3.3 VDC +/- 5%

### Typical Power Consumption (at maximum transmit power setting)

- Transmit: 400 mA (1320mW)
- Receive: 180 mA (594mW)
- Standby: 10 mA (33 mW)

### Operating Temperature

- -30 °C to 75 °C (-22°F to 167°F)

### Operating Humidity

- 10 to 90% (non-condensing)

## Mounting

- 50 pin connector

## Network Standards

- IEEE 802.11b, 802.11g, 802.11i

## Frequency Band

- 2.4 to 2.4897 GHz

## Wireless Media

- Direct Sequence-Spread Spectrum (DSSS)
- Orthogonal Frequency Divisional Multiplexing (OFDM)

## Media Access Protocol

- Carrier sense multiple access with collision avoidance (CSMA/CA)

## Data Rates Supported

- 802.11b (DSSS): 1, 2, 5.5, 11 Mbps
- 802.11g (OFDM): 6, 9, 12, 18, 24, 36, 48, 54 Mbps

## Modulation

- 1, 6, 9 Mbps: BPSK
- 2, 12, 18 Mbps: QPSK
- 5.5, 11 Mbps: CCK
- 24, 36 Mbps: 16-QAM
- 48, 54 Mbps: 64-QAM

## Regulatory Domain Support

- FCC (Americas, Parts of Asia and Middle East)
- ETSI (Europe, Middle East, Africa and Parts of Asia)
- TELEC (Japan) 802.11g (OFDM): 6, 9, 12, 18, 24, 36, 48, 54 Mbps

## Operating Channels

- FCC: 11
- ETSI: 13
- TELEC: 14

## Non-overlapping Channels

- Three

## Transmit Power Settings

**NOTE** Maximum transmit power will vary according to individual country regulations. All values nominal, +/-1.5dBm

- DSSS
  - 19 dBm (80 mW)
  - 17 dBm (50 mW)
  - 15 dBm (30 mW)
  - 10 dBm (10 mW)
  - 0 dBm (1 mW)
- OFDM
  - 15 dBm (30 mW)
  - 10 dBm (10 mW)
  - 0 dBm (1 mW)

## Typical Receiver Sensitivity

- 1 Mbps: -96 dBm
- 2 Mbps: -95 dBm
- 5.5 Mbps: -94 dBm
- 6 Mbps: -94 dBm
- 9 Mbps: -91 dBm
- 11 Mbps: -90 dBm
- 12 Mbps: -88 dBm
- 18 Mbps: -86 dBm
- 24 Mbps: -83 dBm
- 36 Mbps: -78 dBm
- 48 Mbps: -76 dBm
- 54 Mbps: -75 dBm

## Delay Spread

- 1 Mbps: 600 ns
- 2 Mbps: 500 ns
- 5.5 Mbps: 400 ns
- 6 Mbps: 400 ns
- 9 Mbps: 400 ns
- 11 Mbps: 200 ns
- 12 Mbps: 350 ns
- 18 Mbps: 350 ns
- 24 Mbps: 250 ns
- 36 Mbps: 250 ns
- 48 Mbps: 150 ns
- 54 Mbps: 150 ns

## Security

### Standards

- Wireless Equivalent Privacy (WEP)
- Wi-Fi Protected Access (WPA)
- IEEE 802.11i (WPA2)

### Encryption

- Wireless Equivalent Privacy (WEP, RC4 Algorithm)
- Temporal Key Integrity Protocol (TKIP, RC4 Algorithm)
- Advanced Encryption Standard (AES, Rijndael Algorithm)

### Encryption Key Provisioning

- Static (40-bit and 128-bit lengths)
- Pre-Shared (PSK)
- Dynamic

## **802.1X Extensible Authentication Protocol Types**

- EAP-FAST
- EAP-TLS
- PEAP-GTC
- PEAP-MSCHAPv2
- LEAP

## **Compliance**

### **ETSI Regulatory Domain**

- EN 300 328
- EN 301 489
- EN 60590
- EN 50371
- EU 2002/95/EC (RoHS)

### **FCC Regulatory Domain**

- FCC Subpart B, Class B
- FCC Subpart C Part 15.247, 15.207
- ANSI C63.4-2003

### **Industry Canada**

- RSS-210

### **TELECOM Regulatory Domain**

- RCR STD – 33
- ARIB STD - T66
- ARIB STD T71

## **Certifications**

### **Wi-Fi Alliance**

- 802.11b, 802.11g
- WPA Enterprise
- WPA2 Enterprise

### **Cisco Compatible Extensions (CCX)**

- Version 4





## A

---

- AAMI leads
  - part number 5-7
- accessories
  - disposal 2-19
- alligator clips
  - part number 5-8
- archive
  - troubleshooting 3-11

## B

---

- barcode reader
  - calibrating 2-16
  - removing extra carriage return 2-16
  - using with the cardiograph 1-27
- batteries
  - battery status information window 1-23
  - charging 1-22, 1-23
  - charging indicator 1-23
  - installing 1-20
  - maintenance and care 2-10
  - part numbers 5-9
  - replacement 2-11
- battery
  - power indicator 8-14

## C

---

- cables
  - cleaning 2-4, 2-5
- calibration
  - touch screen 2-16, 3-41
- cardiograph
  - disposal 2-19
  - external PC card archive 8-8
  - external remote archive 8-8
  - internal main archive 8-8
  - main board 8-2
  - power indicator 8-14
  - power management 8-13
  - power system overview 8-8, 8-10
  - print controller 8-2
  - troubleshooting 3-2

- cleaning
  - approved cardiograph cleaning solutions 2-3, 2-4
  - cables 2-4, 2-5
  - cardiograph 2-3
  - electrodes 2-4, 2-5
  - lead wires 2-4
  - patient data cable 2-4
  - Patient Interface Module (PIM) 2-3
- compact flash issues
  - troubleshooting 3-22
- CompactFlash
  - diagnostic test 3-45
- configuration screen
  - troubleshooting 3-16
- custom settings issues
  - troubleshooting 3-32
- customer service
  - telephone numbers 5-11

## D

---

- diagnostic test
  - audio 3-45
  - CompactFlash 3-45
  - keyboard 3-45, 4-10
  - onboard flash 3-44
- display
  - troubleshooting 3-4

## E

---

- ECG data flow and storage 8-6
- electrodes
  - cleaning 2-4, 2-5
  - disposable part number 5-8

## F

---

- fax issues
  - troubleshooting 3-31

## H

---

- hardware logical view 8-2

## I

---

- IEC leads
  - part number 5-7
- InCenter web site
  - document errors 1-4
  - downloading Trim I software 6-1
  - errors opening PDF documents 1-4
  - using Adobe Acrobat 1-4
- installing software 6-1

## K

---

- keyboard
  - diagnostic test 3-45, 4-10
  - troubleshooting 3-5

## L

---

- lead wires
  - chest leads part number 5-8
  - cleaning 2-4
  - limb leads part number 5-8
  - open test 3-35
  - short test 3-35
- log file issues
  - troubleshooting 3-32

## M

---

- main board 8-2
- main screen display
  - troubleshooting 3-10
- maintenance
  - batteries 2-10
  - battery replacement 2-11
  - cleaning 2-3
  - touch screen 2-16
  - touch screen calibration 2-16, 3-41
  - touch screen cleaning 2-16
- modem card
  - using with cardiograph 1-25

## O

---

- onboard flash
  - diagnostic test 3-44
- ordering
  - replacement parts 5-1
- orders
  - troubleshooting 3-27

## P

---

- paper
  - part number 5-9
- part numbers
  - replacement parts 5-1
  - supplies 5-7
- patient data cable
  - cleaning 2-4
  - part number 5-7
- Patient Interface Module (PIM)
  - components 1-19
- PC card
  - troubleshooting 3-22
- pediatric tab electrodes 5-9
- Philips InCenter web site
  - document errors 1-4
  - errors opening PDF documents 1-4
- PIM 1-19
  - 12-Lead 1-19
  - diagnostic test 3-43
- power indicator 8-14
- power management 8-13
- power system overview 8-8, 8-10
- print controller 8-2
- printed report
  - red stripe appears 2-7
- printer issues
  - troubleshooting 3-19
- printer paper
  - part number 5-9
  - replacing 2-7
  - tearing 2-10

## R

---

- remote query issues
  - troubleshooting 3-29
- replacement parts
  - ordering 5-1
- replacing
  - batteries 2-11
  - printer paper 2-7

- Response Center, telephone numbers 5-11
- restarting the cardiograph 3-34

## S

---

- signal acquisition issues
  - troubleshooting 3-7
- software
  - installing 6-1
- startup issues
  - troubleshooting 3-3
- supplies
  - part numbers 5-7

## T

---

- technical specifications A-2
- touch screen
  - calibration 2-16, 3-41
  - cleaning 2-16
  - maintenance 2-16
- TraceMasterVue issues
  - troubleshooting 3-25
- troubleshooting
  - archive 3-11
  - compact flash issues 3-22
  - configuration screen 3-16
  - custom settings issues 3-32
  - display 3-4
  - fax issues 3-31
  - keyboard 3-5
  - log file issues 3-32
  - main screen display 3-10
  - orders issues 3-27
  - Philips Response Center phone numbers 5-11
  - printer issues 3-19
  - red stripe on printed report 2-7
  - remote query issues 3-29
  - restarting the cardiograph 3-34
  - signal acquisition issues 3-7
  - start up issues 3-3
  - TraceMasterVue issues 3-25
  - wireless LAN 3-33

## U

---

- USB memory stick
  - cautions 1-25
  - storage capacity 1-26
  - using with cardiograph 1-25

## W

---

- welsh bulb electrodes 5-6
- wireless LAN
  - troubleshooting 3-33
  - using with cardiograph 1-24



Philips Medical Systems  
3000 Minuteman Road  
Andover, MA 01810 USA  
Printed in USA

PageWriter TC70 Cardiograph  
Service Manual for software version  
A.01.00 and higher  
453564106431, Edition 1

